

SONY®

HD DIGITAL VIDEOCASSETTE RECORDER

HDW-S280

HDCAM



MEMORY STICK



OPERATION MANUAL English
1st Edition (Revised 1)

Important Safety Instructions

- Read these instructions.
- Keep these instructions.
- Heed all warnings.
- Follow all instructions.
- Do not use this apparatus near water.
- Clean only with dry cloth.
- Do not block any ventilation openings. Install in accordance with the manufacturer's instructions.
- Do not install near any heat sources such as radiators, heat registers, stoves, or other apparatus (including amplifiers) that produce heat.
- Do not defeat the safety purpose of the polarized or grounding-type plug. A polarized plug has two blades with one wider than the other. A grounding type plug has two blades and a third grounding prong. The wide blade or the third prong are provided for your safety. If the provided plug does not fit into your outlet, consult an electrician for replacement of the obsolete outlet.
- Protect the power cord from being walked on or pinched particularly at plugs, convenience receptacles, and the point where they exit from the apparatus.
- Only use attachments/accessories specified by the manufacturer.
- Use only with the cart, stand, tripod, bracket, or table specified by the manufacturer, or sold with the apparatus. When a cart is used, use caution when moving the cart/apparatus combination to avoid injury from tip-over.
- Unplug this apparatus during lightning storms or when unused for long periods of time.
- Refer all servicing to qualified service personnel. Servicing is required when the apparatus has been damaged in any way, such as power-supply cord or plug is damaged, liquid has been spilled or objects have fallen into the apparatus, the apparatus has been exposed to rain or moisture, does not operate normally, or has been dropped.



WARNING

To prevent fire or shock hazard, do not expose the unit to rain or moisture.

To avoid electrical shock, do not open the cabinet. Refer servicing to qualified personnel only.

THIS APPARATUS MUST BE EARTHED.

CAUTION

The apparatus shall not be exposed to dripping or splashing and no objects filled with liquid, such as vases, shall be placed on the apparatus.

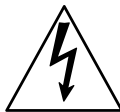
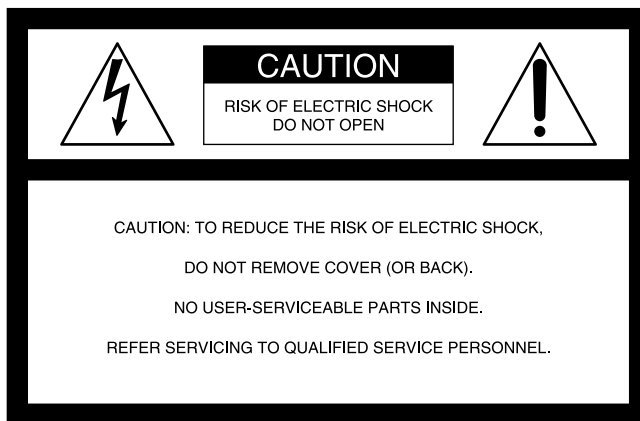

This symbol is intended to alert the user to the presence of uninsulated "dangerous voltage" within the product's enclosure that may be of sufficient magnitude to constitute a risk of electric shock to persons.



This symbol is intended to alert the user to the presence of important operating and maintenance (servicing) instructions in the literature accompanying the appliance.

WARNING: THIS WARNING IS APPLICABLE FOR USA ONLY.

If used in USA, use the UL LISTED power cord specified below.

DO NOT USE ANY OTHER POWER CORD.

Plug Cap	Parallel blade with ground pin (NEMA 5-15P Configuration)
Cord	Type SJT, three 16 or 18 AWG wires
Length	Minimum 1.5m, Less than 2.5 m (8 ft. 3 in.)
Rating	Minimum 10A, 125V

Using this unit at a voltage other than 120V may require the use of a different line cord or attachment plug, or both. To reduce the risk of fire or electric shock, refer servicing to qualified service personnel.

WARNING: THIS WARNING IS APPLICABLE FOR OTHER COUNTRIES.

1. Use the approved Power Cord (3-core mains lead) / Appliance Connector / Plug with earthing-contacts that conforms to the safety regulations of each country if applicable.
2. Use the Power Cord (3-core mains lead) / Appliance Connector / Plug conforming to the proper ratings (Voltage, Ampere).

If you have questions on the use of the above Power Cord / Appliance Connector / Plug, please consult a qualified service personnel.

For the customers in the U.S.A.

This equipment has been tested and found to comply with the limits for a Class A digital device, pursuant to Part 15 of the FCC Rules. These limits are designed to provide reasonable protection against harmful interference when the equipment is operated in a commercial environment. This equipment generates, uses, and can radiate radio frequency energy and, if not installed and used in accordance with the instruction manual, may cause harmful interference to radio communications. Operation of this equipment in a residential area is likely to cause harmful interference in which case the user will be required to correct the interference at his own expense.

You are cautioned that any changes or modifications not expressly approved in this manual could void your authority to operate this equipment.

The shielded interface cable recommended in this manual must be used with this equipment in order to comply with the limits for a digital device pursuant to Subpart B of Part 15 of FCC Rules.

For the customers in the USA and Canada

• RECYCLING LITHIUM-ION BATTERIES

Lithium-Ion batteries are recyclable. You can help preserve our environment by returning your used rechargeable batteries to the collection and recycling location nearest you.



For more information regarding recycling of rechargeable batteries, call toll free 1-800-822-8837, or visit <http://www.rbrcc.org/>

Caution: Do not handle damaged or leaking lithium-ion batteries.

• RECYCLING NICKEL METAL HYDRIDE BATTERIES

Nickel metal hydride batteries are recyclable. You can help preserve our environment by returning your used rechargeable batteries to the collection and recycling location nearest you.



For more information regarding recycling of rechargeable batteries, call toll free 1-800-822-8837, or visit <http://www.rbrcc.org/>

Caution: Do not handle damaged or leaking lithium-ion batteries.

For the customers in Europe

This product with the CE marking complies with both the EMC Directive (89/336/EEC) and the Low Voltage Directive (73/23/EEC) issued by the Commission of the European Community. Compliance with these directives implies conformity to the following European standards:

- EN60065: Product Safety
- EN55103-1: Electromagnetic Interference (Emission)
- EN55103-2: Electromagnetic Susceptibility (Immunity)

This product is intended for use in the following Electromagnetic Environment(s):

E1 (residential), E2 (commercial and light industrial), E3 (urban outdoors) and E4 (controlled EMC environment, ex. TV studio).

CAUTION

The unit is not disconnected from the AC power source (mains) as long as it is connected to the wall outlet, even if the unit itself has been turned off.

For the customers in Taiwan only



廢電池請回收

Voor de Klanten in Nederland



Gooi de batterij niet weg maar lever deze in als klein chemisch afval (KCA).

Table of Contents

Chapter 1 Overview

1-1	Features	8
1-2	System Configurations	9
1-3	Using the CD-ROM Manual.....	10
1-3-1	CD-ROM System Requirements	10
1-3-2	Preparations	10
1-3-3	Reading the CD-ROM Manual.....	10

Chapter 2 Names and Functions of Parts

2-1	Front Panel	11
2-1-1	Menu Operation Section.....	12
2-1-2	Tape Transport Section	13
2-1-3	Display Window.....	14
2-2	Rear Panel.....	18

Chapter 3 Preparations

3-1	Preparing Power Sources.....	20
3-1-1	Supplying Power	20
3-1-2	Using the BP-GL65/GL95 Battery Pack	21
3-2	Using a Stand	22
3-3	Connections	23
3-4	Handling Cassettes	24
3-4-1	Usable Cassettes	24
3-4-2	Loading/Ejecting Cassettes	24
3-4-3	Preventing Accidental Erasures.....	24
3-5	Setting Reference Video Signals	25
3-6	Setting Timecode	26
3-6-1	Setting an Initial Value and Recording Timecode	26
3-6-2	Synchronizing the Internal Timecode Generator with an External Signal	27
3-6-3	Synchronizing the Internal Timecode Generator with a Playback Timecode – Timecode Recording during Auto Editing	28
3-6-4	Converting Timecode in 24- or 25-Frame Mode Playback (TC CONV)	28

3-7	Basic Operations of the Function Menu	29
3-7-1	Configuration of the Function Menu	29
3-7-2	Function Menu Item List	30
3-7-3	Basic Operations	33
3-8	Superimposed Character Information	34
3-9	Using a "Memory Stick"	36
3-9-1	Notes on "Memory Stick"	36

Chapter 4 Recording and Playback

4-1	Recording	38
4-1-1	Preparations for Recording	38
4-1-2	Recording Operation.....	38
4-2	Back Space Editing.....	39
4-3	Sequential Recording	39
4-4	Playback	41
4-4-1	Preparations for Playback	41
4-4-2	Playback Operation.....	41
4-4-3	Jog/Shuttle Mode playback.....	42

Chapter 5 Assemble Editing

5-1	Overview	43
5-1-1	Assemble Editing	43
5-2	Automatic Editing	43
5-2-1	Setting the Edit Points	43
5-2-2	Modifying and Deleting Edit Points	44
5-2-3	Cueing up to Edit Points and Prerolling	45
5-2-4	Preview	46
5-2-5	Performing Automatic Editing	47
5-2-6	First Edit Function	48

Chapter 6 Shot Mark/Shot Data

6-1	Overview	49
6-1-1	Shot Mark/Shot Data Function Features.....	49

Chapter 7 Stop Code

7-1	Stop Code	50
7-2	Stop Code Operation	50
7-2-1	Detecting the Stop Code.....	50
7-2-2	Recording the Stop Code.....	51
7-2-3	Erasing the Stop Code	52
8-1	Overview of UMID Functions.....	53
8-2	Recording UMIDs	53

Chapter 8 UMID Functions

8-3	UMID Output and Display	56
8-3-1	UMID Output Settings	56
8-3-2	UMID Display	56

Chapter 9 Setup Menus

9-1	Setup Menu Configuration	58
9-2	Setup Menu Operations	58
9-2-1	Displaying Setup Menus	58
9-2-2	Setting Setup Menu	59
9-2-3	Menu Bank Operations (menu items B01 to B12)	60
9-3	Items in the Basic Setup Menu	61
9-4	Items in the Extended Setup Menu.....	64

Chapter 10 Maintenance and Inspection

10-1	Removing a Cassette When Tape Slack Occurs .	77
10-2	Head Cleaning	77
10-3	Error Messages	78
10-4	Warning Messages.....	80
10-5	Moisture Condensation	81
10-6	Regular Checks	81
10-6-1	Digital Hours Meter.....	81
10-6-2	Maintenance Timings	82

Appendixes

Specifications.....	84
Index	89

For the customers in the U.S.A. and Canada

Note (Video set up amount)

The video setup amount is set to 0% at the factory. If necessary, you can change the amount using setup menu item 713.

For details on setup menu item 713, see page 72.

Overview

Chapter

1

1-1 Features

The HDW-S280 is a digital portable videocassette recorder for the HDCAM format.

The unit has the features described below.

Rich variety of input and output signals

The HD4:2:2 component video signal is input as an HD-SDI signal based on the SMPTE292M standards and is recorded in HDCAM format. The following input and output signals are supported:

- HD-SDI (high-definition serial digital interface) video and four-channel audio input and output
- SDI video and four-channel audio output
- SD composite output
- Two-channel analog audio input and output
- Timecode input and output
- Reference-signal input and loop-through output

Compact size replaceable with a DNW-A28

The HDW-S280 HDCAM format portable video recorder has the same size, weight, and power consumption as the DNW-A28 Betacam SX format portable video recorder, which enables you to replace a DNW-A28 with this unit. The unit accepts an S cassette.

Playback compatibility with Betacam, Betacam SP, Betacam SX

Besides recording and playback in HDCAM format, it can play tapes recorded in Betacam, Betacam SP, or Betacam SX formats, allowing you to make effective use of Betacam, Betacam SP, and Betacam SX cassettes recorded in the past.

Control Panel

The unit is equipped with an LCD monitor on the front panel, which enables you to view materials on the unit without using an external video monitor. The jog and shuttle functions using the search dial allow searching for a desired picture easily for effective cueing up and editing.

AC and DC power

The unit can be operated with a variety of power sources, such as DC power using a battery pack or an AC adaptor and an AC power source. Applicable battery packs are the

BP-GL65/GL95 and BP-L60(A)/L90(A) (lithium-ion batteries) and BP-M50/M100 (nickel hydrate batteries). The unit can operate for about 80 minutes with a BP-GL95 battery pack mounted. To mount a battery pack, attach an optional BKP-L551 Battery Adaptor.

Built-in up-converter and down-converter

The HDW-S280 has a built-in up-converter to convert SD format to the HD format and down-converter to convert HD format to the SD format. When an SD-format tape is played, the signal is converted to HD format and output. When an HD-format tape is played, the signal is converted to SD format and output.

If the system frequency is set to 24PsF or 23.98PsF, the down-converted signal is not output.

Assemble editing

By connecting two HDW-S280 units, you can perform assemble editing. For improved effect efficiency, various functions such as setting and modifying edit points, preview, and review, are available.

Both interlace and progressive recording/playback

When using the HDCAM format, 59.94i, 50i, 29.97PsF, 25PsF, 24PsF, and 23.98PsF mode recording and playback can be selected from a menu. When 59.94i or 29.97PsF is selected, a Betacam SX cassette recorded in NTSC or analog Betacam cassette can be played. When 50i or 25PsF is selected, a Betacam SX cassette recorded in PAL or analog Betacam cassette can be played. Characteristics of a Betacam SP cassette recorded in PAL in 50i or 25PsF mode are the same as those when a Betacam cassette is played.

1-2 System Configurations

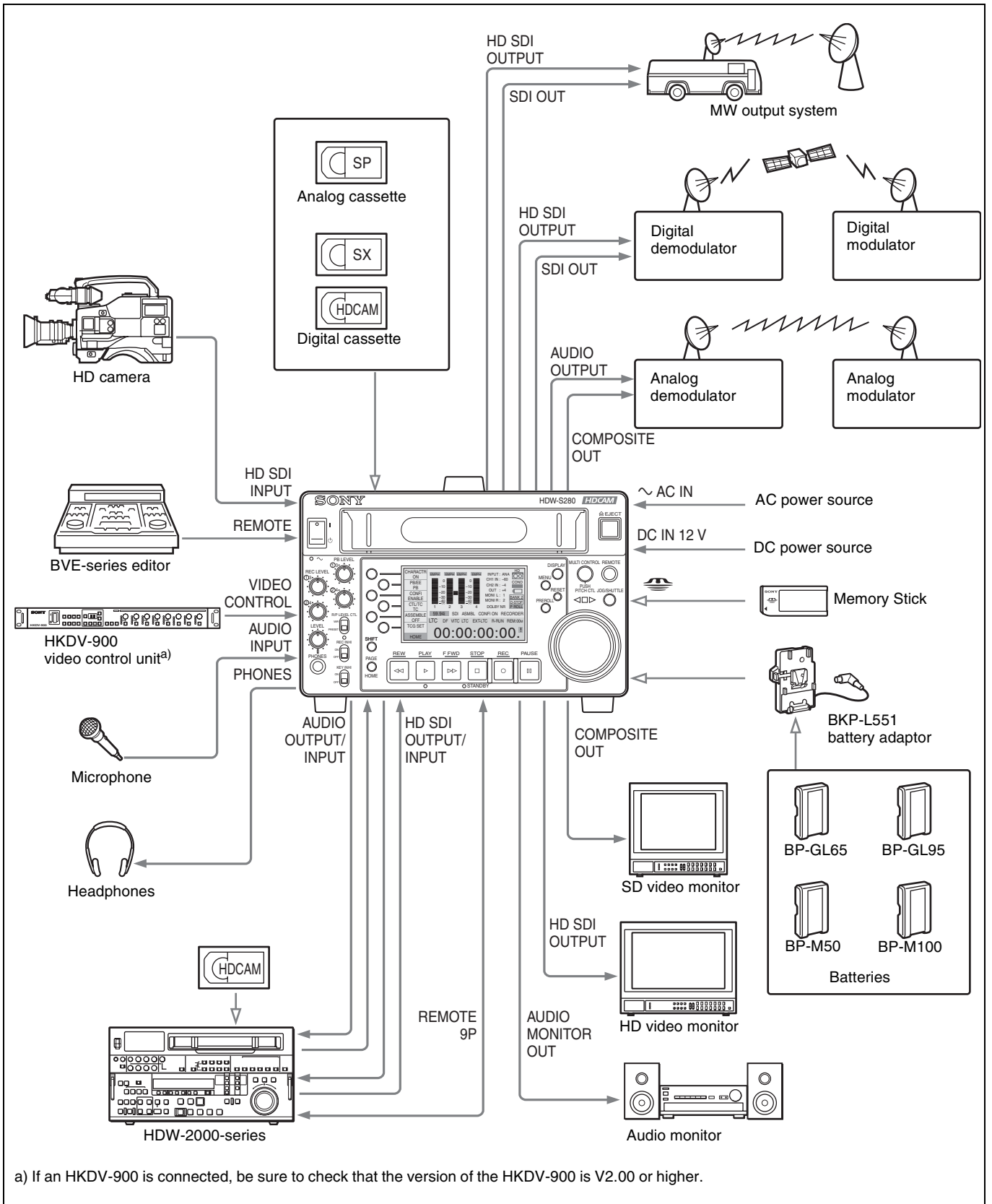

a) If an HKDV-900 is connected, be sure to check that the version of the HKDV-900 is V2.00 or higher.

1-3 Using the CD-ROM Manual

The supplied CD-ROM includes versions of the Operation Manual for the HDW-S280 (Japanese, English, French, and German versions).

1-3-1 CD-ROM System Requirements

The following are required to access the supplied CD-ROM disc.

- Computer: PC with Intel Pentium CPU
 - Installed memory: 64 MB or more
 - CD-ROM drive: ×8 or faster
- Monitor: Monitor supporting resolution of 800 × 600 or higher
- Operating system: Microsoft Windows Millennium Edition, Windows 2000 Service Pack 2, Windows XP Professional or Windows XP Home Edition

When these requirements are not met, access to the CD-ROM disc may be slow, or not possible at all.

1-3-2 Preparations

One of the following programs must be installed on your computer in order to use the operation manuals contained on the CD-ROM disc.

- Adobe Acrobat Reader Version 4.0 or higher
- Adobe Reader Version 6.0 or higher

Note

If Adobe Reader is not installed, you can download it from the following URL:
<http://www.adobe.com/>

1-3-3 Reading the CD-ROM Manual

To read the operation manual contained on the CD-ROM disc, do the following:

- 1** Insert the CD-ROM disc in your CD-ROM drive.

A cover page appears automatically in your browser. If it does not appear automatically in the browser, double-click the index.htm file on the CD-ROM disc.

- 2** Select and click the operation manual that you want to read.

This opens the PDF file of the operation manual.

Note

If you lose the CD-ROM disc or become unable to read its content, for example because of a hardware failure, you can do one of the following:

- You can purchase a new CD-ROM disc to replace one that has been lost or damaged. Contact your Sony service representative.
- You can purchase printed versions of the operation manuals (English version). Contact your Sony service representative.

When ordering, be sure to specify the part number of the manual you want.

Part No.	Model covered
3-857-685-0X	HDW-S280

- Intel and Pentium are registered trademarks of Intel Corporation or its subsidiaries in the United States and other countries.
- Microsoft and Windows are registered trademarks of Microsoft Corporation in the United States and/or other countries.
- Adobe, Acrobat, and Adobe Reader are trademarks of Adobe Systems Incorporated in the United States and/or other countries.

2-1 Front Panel

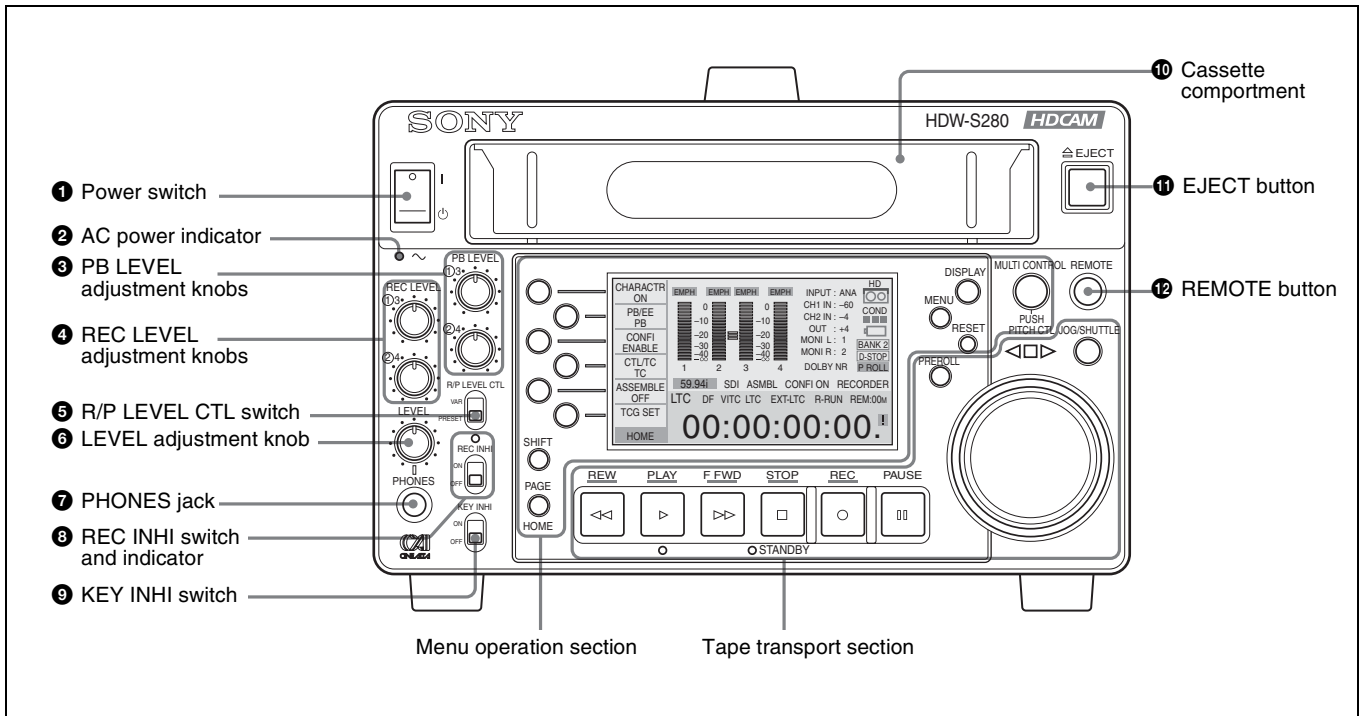

1 Power switch

Turns the unit ON and OFF.

For details, see “3-1-1 Supplying Power” on page 20.

2 AC power indicator

Lights while the POWER switch on the rear panel is set to ON and AC power is supplied.

3 PB LEVEL adjustment knobs

Adjust the audio playback level by channel for channels 1 to 4 when the R/P LEVEL CTL switch is set to VAR. Which channels can be adjusted is set with setup menu item 826.

For details on setup menu item 826, see page 74.

4 REC LEVEL adjustment knobs

Adjust the audio recording level by channel for audio input to this unit when the R/P LEVEL CTL switch is set to VAR. Which channels can be adjusted is set with setup menu item 826.

For details on setup menu item 826, see page 74.

The PB LEVEL adjustment knobs and REC LEVEL adjustment knobs can be used for controlling four-channel recording level or four-channel playback level if you set this option with setup menu item 826. In this case, each knob controls channel indicated below.

Adjustment knob	Recording channel	Playback channel
REC LEVEL ①	Channel 1	Channel 3

Adjustment knob	Recording channel	Playback channel
REC LEVEL ②	Channel 2	Channel 4
PB LEVEL ①	Channel 3	Channel 1
PB LEVEL ②	Channel 4	Channel 2

⑤ R/P LEVEL CTL switch

VAR: Enables adjustment with the PB LEVEL adjustment knobs or REC LEVEL adjustment knobs while you view the audio level meter in E-E mode.

PRESET: Presets to fixed levels. Levels cannot be adjusted with the PB LEVEL adjustment knobs or REC LEVEL adjustment knobs.

For Switching to E-E mode, see “To monitor in E-E mode” on page 14.

⑥ LEVEL adjustment knob

Adjusts the volume of the headphones connected to the PHONES jack.

⑦ PHONES (headphones) jack

Connect headphones.

⑧ REC INHI switch and indicator

ON: Recording on the tape is inhibited, regardless of the state of the cassette’s erasure prevention plug. The REC INHI indicator lights.

OFF: Recording on the tape is enabled when the cassette’s erasure prevention plug is set to the original position.

⑨ KEY INHI switch

When this switch is set to ON, the functions of the buttons selected with setup menu item 118 are inhibited.

For details on setup menu item 118, see page 64.

⑩ Cassette compartment

Insert a cassette here.

⑪ EJECT button

Press to eject the cassette. The cassette mark in the display window flashes while the cassette is being ejected.

⑫ REMOTE button

Selects the operation mode of this unit.

When the button is not lit, the unit is controlled from the front panel of this unit. Normally use this status.

When the button has been pressed and is lit, this unit is controlled from the device connected to the REMOTE 9P connector. In this case, all VTR operations using this unit’s front panel are disabled except those of the STOP and EJECT buttons.

When two HDW-S280 units are connected, press this button on the player VTR to make it lit.

You can determine which tape transport buttons on the front panel are to be enabled when the REMOTE button is lit with setup menu item 006.

For details on setup menu item 006, see page 61.

2-1-1 Menu Operation Section

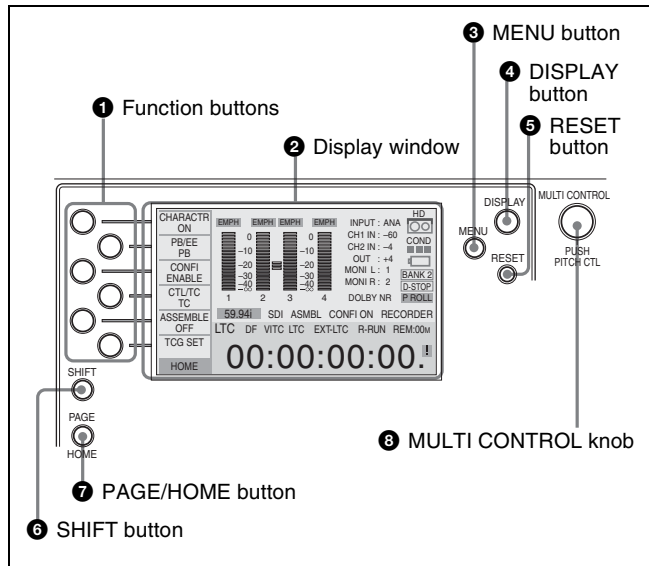

① Function buttons

Select and set menu items displayed in the display window.

② Display window

Displays menus, audio level meters, and data such as time data or meta-data. The DISPLAY button let you switch to the video monitor display.

For details, see “2-1-3 Display Window” on page 14.

③ MENU button

Displays a setup menu item in the time data display area of the display window.

For details on the setup menu operations, see “9-2 Setup Menu Operations” on page 58.

④ DISPLAY button

Switches the operation display to the video monitor display and vice versa.

⑤ RESET button

Resets the CTL data displayed in the display window or the initial value of the timecode generator.

⑥ SHIFT button

Switches between functions for any button with two functions.

7 PAGE/HOME button

Switches pages of the function menu. When you press this button together with the SHIFT button, the HOME page of the function menu is displayed.

8 MULTI CONTROL knob

Sets value for the menu or timecode. When you press the knob, the units for adjustment become larger, and when you press it again, the unit return to the original value.

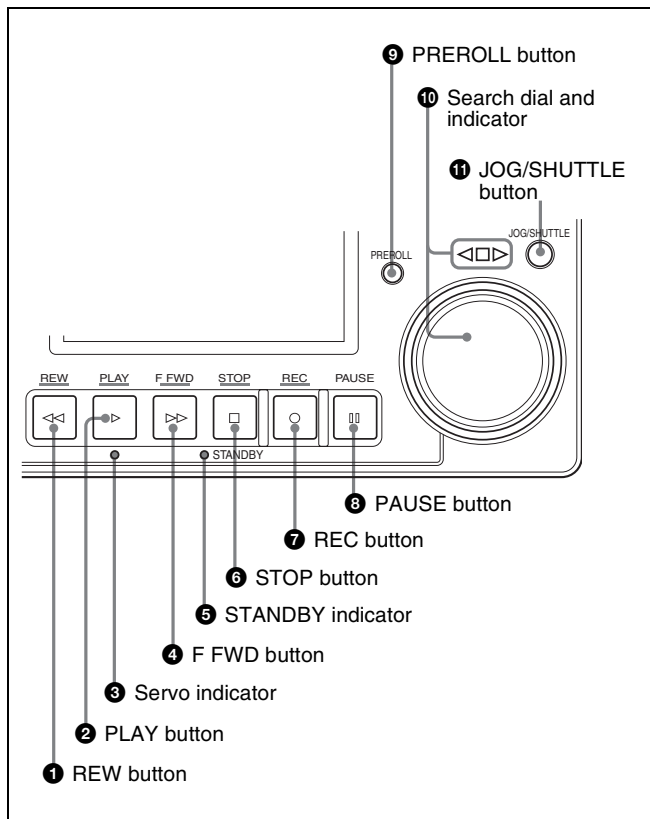
2-1-2 Tape Transport Section**1 REW (rewind) button**

Press this button to rewind the tape. When using a tape on which shot marks have been recorded, pressing this button together with the SHIFT button cues up the previous shot mark position.

2 PLAY button

Press this button to start playback. Recording starts when you press this button together with the REC button. If you press this button only during recording, recording stops, and the unit enters playback mode. When a Betacam SX cassette is being played, pressing this button together with the SHIFT button displays the shot data on the video monitor. The shot data can be superimposed on the character information.

3 Servo indicator

Lights while the drum servo and capstan servo are locked.

4 F FWD (fast forward) button

Press this button to fast-forward a tape. When using a tape on which shot marks have been recorded, pressing this button together with the SHIFT button cues up the next shot mark position.

5 STANDBY indicator

Lights while the tape drum is rotating with tension applied (standby on). It goes dark when the drum stops rotating and tension is released (standby off).

To protect the tape, the unit normally changes to standby off mode when stop or pause mode continues for longer than eight minutes. If you operate a search dial or any of the tape transport buttons other than the PAUSE button while the unit is in standby off mode, the unit changes to standby on mode and enters the mode called by the button or dial that you pressed.

By pressing the SHIFT button together with the STOP button, you can switch between standby on and standby off mode manually.

Tape protection settings are made with setup menu items 500s.

For details on the setup menu items 500s, see page 67.

6 STOP button

Press to stop playback or recording. When you stop playback, the monitor displays E-E or still picture playback, depending on the settings for PB/EE on the HOME page of the function menu.

By pressing this button together with the SHIFT button, you can switch between standby on and standby off mode manually.

When setup menu item 105 is set to ON, this button flashes if the reference video signal specified by OUT REF on the P2 VIDEO page of the function menu or setup menu item 309 is not being input.

For details on setup menu item 105, see page 64 and for 309, see page 66.

For details on the settings for PB/EE and OUT REF of the function menu, see “3-7 Basic Operations of the Function Menu” on page 29.

For more details on the reference video signal settings, see “3-5 Setting Reference Video Signals” on page 25.

7 REC (record) button

Press together with the PLAY button to start recording. When two HDW-S280 units are connected, this button allows you to perform sequential recording from one unit to the other.

For details, see “4-3 Sequential Recording” on page 39.

To monitor in E-E mode

You can monitor input signals in E-E mode by pressing this button in stop mode. The button lights when pressed. To return to the original picture, press the STOP button. You can view E-E video during playback, search, fast forward, and rewind while pressing this button.

Note

When a Betacam, Betacam SP or Betacam SX tape is played, you cannot monitor E-E video.

8 PAUSE button

Pauses an operation (when pressed during recording or playback). You can execute back space editing with use of this button.

For details on back space editing, see “4-2 Back Space Editing” on page 39.

9 PREROLL button

Cues up the preroll point. You can set the preroll time and the status after prerolling with setup menu items 001 and 401.

For details on the setup menu item 001, see page 61, and for 401, see page 67.

10 Search dial and indicator

The outer ring is for shuttle playback, and the inner dial is for jog playback. Press the JOG/SHUTTLE button to make it lit and turn the ring or dial for playback in jog or shuttle mode. Turning the dial clockwise plays a tape in the forward direction (the ▷ indicator lights). Turning the dial counterclockwise plays a tape in the reverse direction (the ◁ indicator lights). When the tape stops, the □ indicator lights.

Setting for setup menu item 101 enables a direct search operation that enables the search dial operation without pressing the JOG/SHUTTLE button (direct jog/shuttle mode).

For details on setup menu item 101, see page 64.

11 JOG/SHUTTLE button

Press to enter search mode. Each time you press this button, jog and shuttle mode are toggled, and the selected mode is indicated in the display window.

2-1-3 Display Window

Operation display

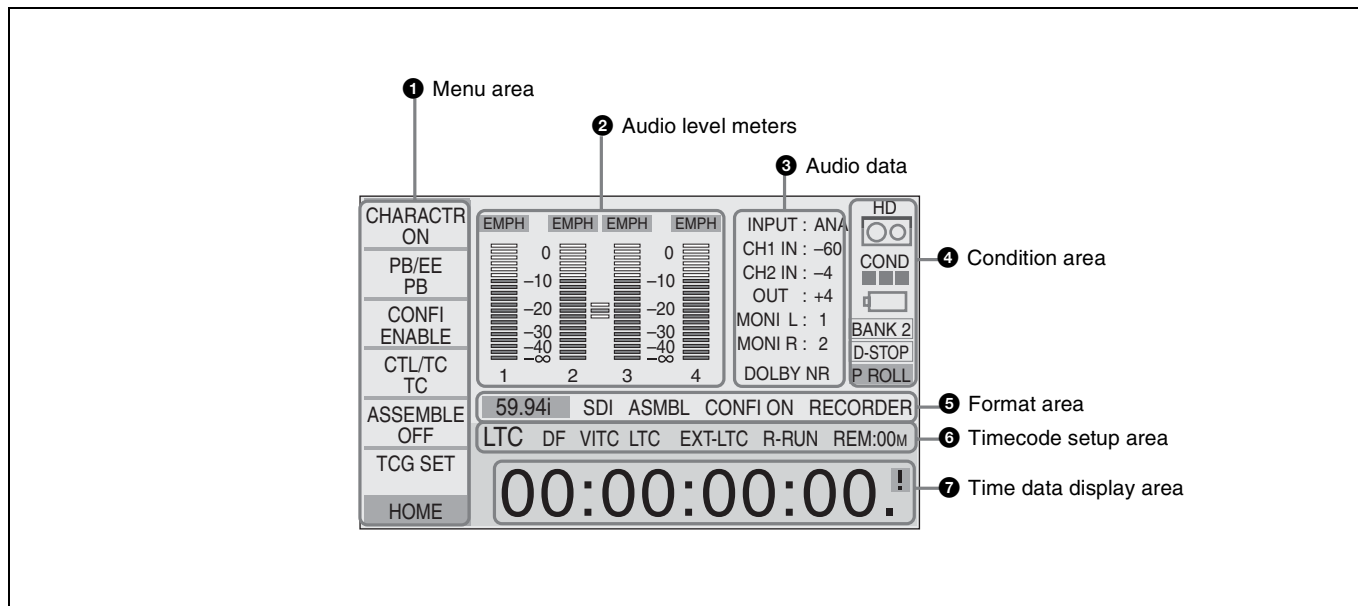

1 Menu area

Normally displays the function menu. When you press the MENU button, the functions of the function buttons used in setup menu operations are indicated. Depending on the function of the button, a white bar lights or flashes below the function name to indicate the current status.

2 Audio level meter

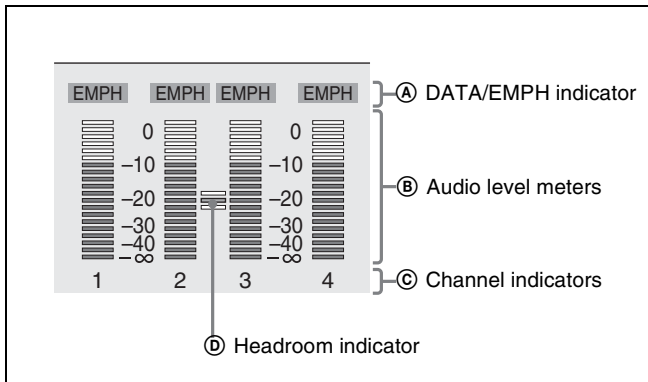

A DATA/EMPH indicator

DATA: Lights if an audio signal is recognized as a data signal in record, E-E or play mode.

EMPH: Lights if EMPHASIS on the P3 AUDIO page of the function menu is set to ON.

B Audio level meters

Display the recording and playback audio levels of the four audio channels (CH-1 to CH-4).

C Channel indicators

Display the audio channels. The channels selected with setup menu item 826 are shown in green to indicate that they are adjustable.

For details on setup menu item 826, see page 74.

D Headroom indicator

Displays the headroom for the audio circuit set with maintenance menu item M370.

For details on the maintenance menu item M370 refer to the maintenance manual.

3 Audio data

Displays the audio data.

INPUT: Input signal selected with AUDIO IN on the P3 AUDIO page of the function menu.

CH1 IN: Input audio level for channel 1 set with the setup menu item 834.

CH2 IN: Input audio level for channel 2 set with the setup menu item 834.

OUT: Output audio level set with the setup menu item 812.

MONI L: Monitor output for left channel set with MONITR L on the P3 AUDIO page of the function menu.

MONI R: Monitor output for right channel set with MONITR R on the P3 AUDIO page of the function menu.

DOLBY NR: Lights when DOLBY NR on the P3 AUDIO page of the function menu is set to ON and when an oxide tape is used.

Dolby noise reduction manufactured under license from Dolby Laboratories Licensing Corporation.

"Dolby" and the double-D symbol are trademarks of Dolby Laboratories Licensing Corporation.

4 Condition area

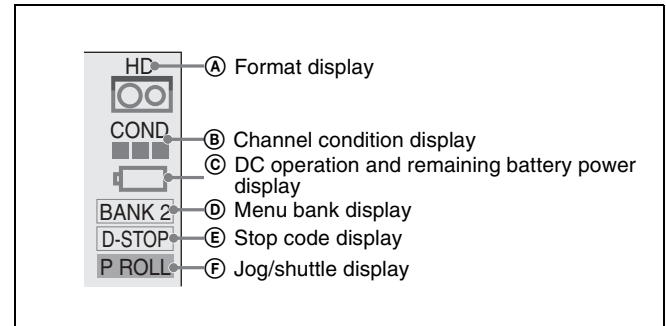

A Format display

Displays the format of the cassette in use. When a cassette is being ejected, the cassette mark flashes. If you start recording while a Betacam SX, Betacam SP, or Betacam cassette is being ejected, the cassette mark flashes.

B Channel condition display

Displays the playback condition on a scale of three levels.

C DC operation and remaining battery power display

Lights while the unit is operating on DC power.

When the unit is operated with a battery pack, a slash is displayed and flashes when the battery power is nearly exhausted.

D Menu bank display

Shows the menu bank number that has the same menu data as currently being used.

E Stop code display

Lights when a stop code can be detected. When the stop code is detected, the display flashes. When you cue up the shot mark, the type of the cued-up shot mark appears.

F Jog/shuttle display

JOG: Lights in jog mode or when jog mode is selected when the JOG/SHUTTLE button is pressed.

SHTL: Lights in shuttle mode or when shuttle mode is selected when the JOG/SHUTTLE button is pressed.

P ROLL: Lights during prerolling.

5 Format area

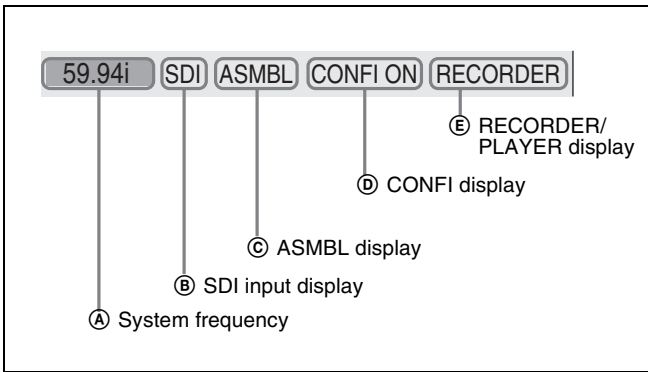

(A) System frequency

Displays the system frequency for recording selected with setup menu item 013.

For details on setup menu item 013, see page 62.

(B) SDI input display

Lights when VIDEO IN on the P2 VIDEO page of the function menu is set to SDI and an SDI signal is being input. If an SDI signal is not input, it flashes.

(C) ASMBL display

Lights when ASSEMBLE on the HOME page of the function menu is set to ON.

(D) CONF I display

Lights when CONF I on the HOME page of the function menu is set to ENABLE. During confidential playback, CONF I ON is lit.

(E) RECORDER/PLAYER display

Lights according to the settings of R/P on the P5 EDIT page of the function menu. PARA RUN appears in PARA RUN operations, and two VTRs are controlled simultaneously.

If setup menu item 214 is set to SDI and the REMOTE button is lit, SDI RMT appears. It flashes if an HD-SDI signal is not input, and is continuously displayed if a VTR control signal of the HD-SDI signal is recognized. During sequential recording, SEQ RC appears.

For details on the settings of the function menu, see “3-7 Basic Operations of the Function Menu” on page 29.

For details on the setting for PARA RUN, see setup menu item 201 on page 65.

For details on setup menu item 214, see page 65.

6 Timecode setup area

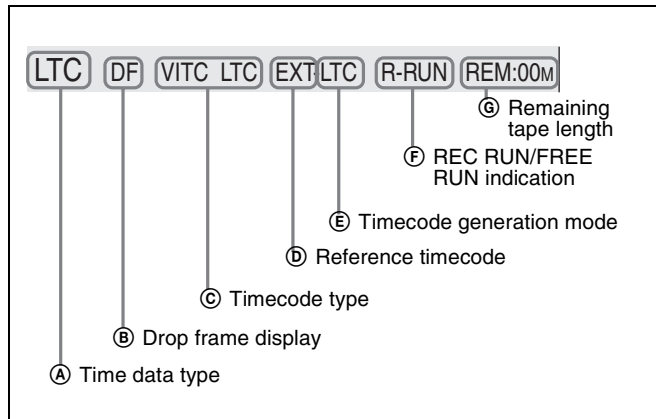

(A) Time data type

Displays the type of time data displayed in the time data display area.

(B) Drop frame display

DF appears when a tape recorded in drop frame mode is played.

(C) Timecode type

When VITC is read during playback, VITC is displayed. When LTC is read, LTC is displayed. During recording, the type of timecode being recorded appears. In E-E mode, if the timecode to be recorded can be read, it is displayed.

(D) Reference timecode

Displays the setting for TCG on the P4 TC page of the function menu (INT, EXT or SDI).

(E) Timecode generation mode

Displays the setting for PRST/RGN on the P4 TC page of the function menu (PRESET, LTC, or VITC).

(F) REC RUN/FREE RUN indication

Displays the setting for RUN on the P4 TC page of the function menu (FREE or REC).

(G) Remaining tape length

Displays the amount of tape remaining in meters.

For details on the settings of the function menu, see “3-7 Basic Operations of the Function Menu” on page 29.

7 Time data display area

Displays the time data. During setup menu operations, time data appears in the upper half, and the menu item appears in the lower half.

Video monitor display

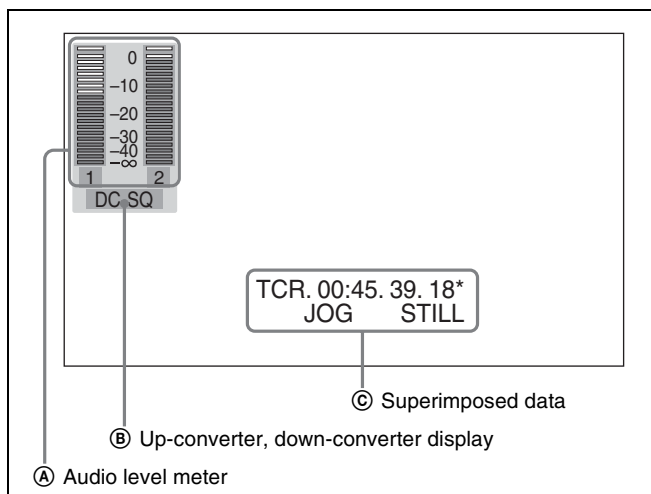

When you press the DISPLAY button, the display window changes to the video monitor display.

(A) Audio level meter

LEVEL MT on the P3 AUDIO page of the function menu decides whether the meter is to be displayed and on which side, left or right, it is displayed in the display window.

(B) Up-converter, down-converter display

If setup menu item 140 is set to ON, up-convert or down-convert mode appears.

DC-EC: Edge-crop mode of the down-convert mode

DC-LB: Letter box mode of the down-convert mode

DC-SQ: Squeeze mode of the down-convert mode

UC-EC: Edge-crop mode of the up-convert mode

UC-LB: Letter box mode of the up-convert mode

UC-SQ: Squeeze mode of the up-convert mode

For details on setup menu item 140, see page 65.

(C) Superimposed data

Appears when CHARACTER on the HOME page of the function menu is set to ON.

Picture frame in playback

The frame when an SD cassette is played can be selected with setup menu item 950.

EDGE-CROP:

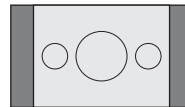

LETTER BOX:

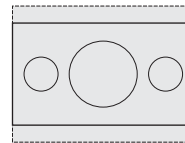

SQUEEZE:

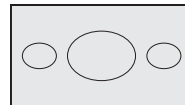

For details on the settings of LEVEL MT and CHARACTER of the function menu, see "3-7 Basic Operations of the Function Menu" on page 29.

For details on setup menu item 950, see page 76.

2-2 Rear Panel

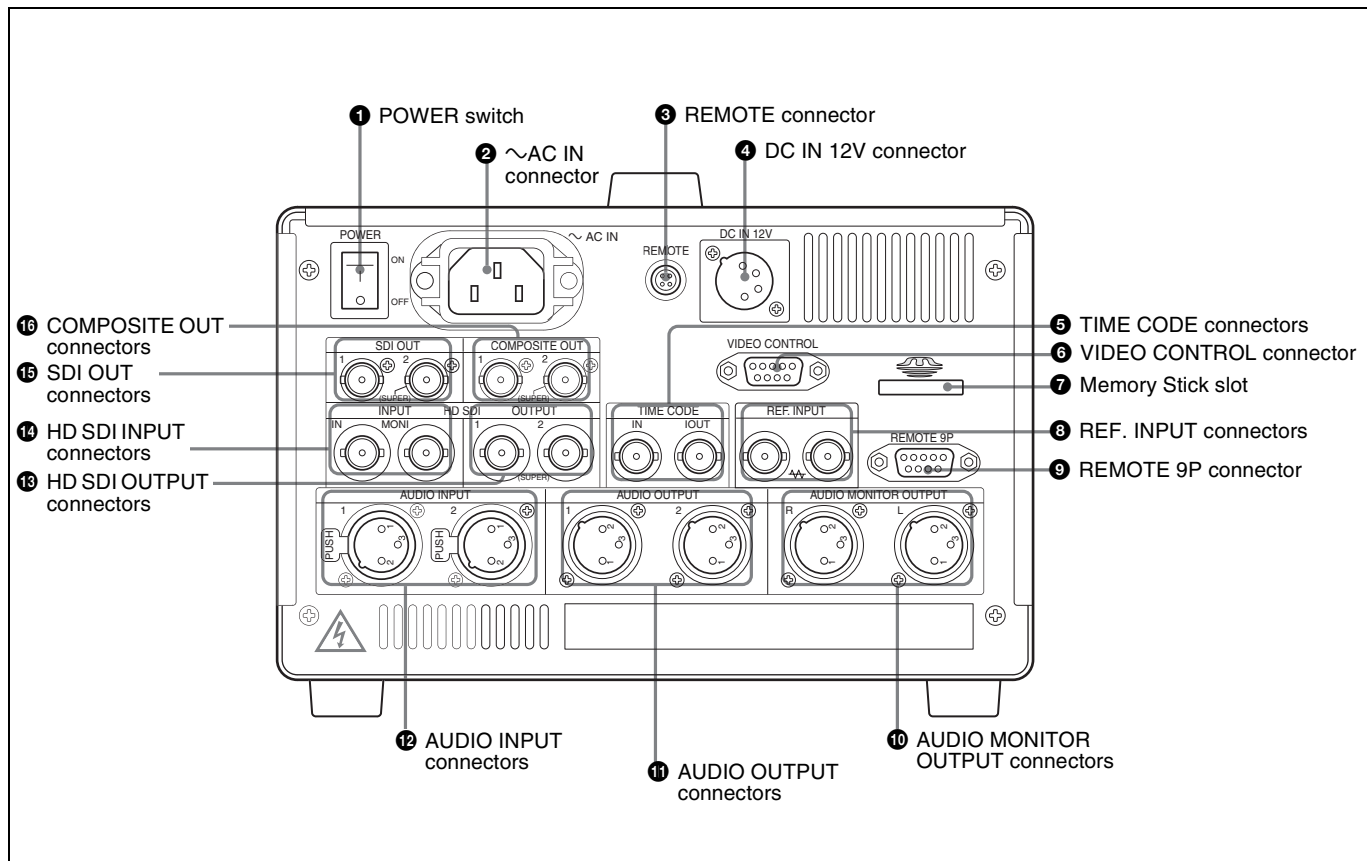

1 POWER switch

Turns the AC power supply ON/OFF.

For details, see “3-1-1 Supplying Power” on page 20.

2 ~AC IN connector

Connect to an AC power source using an AC power cord.

3 REMOTE connector (4-pin)

Supplies power of 15 V or 12V DC to the BVR-3 Remote Control Unit.

4 DC IN 12V connector (XLR 4-pin, male)

Connect to a DC power source of 12V.

When using the BKP-L551 Battery Adaptor to mount a battery pack, connect the power cable of the BKP-L551.

For details, see “3-1-1 Supplying Power” on page 20.

5 TIME CODE connectors (BNC type)

IN: To record a timecode from an external device, input the timecode from the external device.

OUT: Outputs the following types of timecode, depending on the VTR’s operating status.

During playback: The playback timecode

During recording: The timecode generated by the internal timecode generator or the timecode input via the TIME CODE IN connector.

6 VIDEO CONTROL connector (D-SUB 9-pin)

Connect an HKDV-900 video control unit.

7 Memory Stick slot

Insert a Memory Stick.

8 REF. INPUT (reference video signal input) connectors (BNC type)

Input a reference video signal, a three-valued (positive and negative) sync signal, a video signal with color burst (VBS), or a black-and-white video signal (VS). When the signal is bridged, termination is automatically set to OFF.

Note

Be sure to use the unit for frame synchronization only, not for color subcarrier synchronization.

9 REMOTE 9P connector (D-SUB 9-pin)

When editing using two HDW-S280 units, connect a 9-pin remote control cable (not supplied) to this connector of

each unit. For editing using this unit and an HDCAM VTR, connect the external equipment.

10 AUDIO MONITOR OUTPUT connectors (XLR 3-pin, male)

Output the audio signals of the channels selected with the MONITR L and MONITR R on the P3 AUDIO page of the function menu.

For details on the MONITR L and MONITR R settings, see “3-7 Basic Operations of the Function Menu” on page 29.

11 AUDIO OUTPUT connectors (XLR 3-pin, male)

Output the analog audio signals of the channels selected with setup menu item 824.

For details on setup menu item 824, see page 74.

12 AUDIO INPUT connectors (XLR 3-pin, female)

Input the analog audio signals.

13 HD SDI (high-definition serial digital interface) OUTPUT connectors (BNC type)

Output the HD-SDI format video/audio signal. When editing with two HDW-S280 units, connect a cable between these connectors on the player VTR and the HD SDI INPUT connectors on the recorder VTR.

You can superimpose timecodes, menu settings, error messages, or other information on the output of these connectors with the setting for CHARACTER on the HOME page of the function menu or with the setting for setup menu item 028. You can always disable to superimpose the data independent of the setting for CHARACTER with the setting for setup menu item 028.

For details on CHARACTER setting, see “3-7 Basic Operations of the Function Menu” on page 29.

For details on the setup menu item 028, see page 62.

14 HD SDI (high-definition serial digital interface) INPUT connectors (BNC type)

Input the HD-SDI format video/audio signal. When editing with two HDW-S280 units, connect a cable between these connectors on the recorder VTR and the HD SDI OUTPUT connectors on the player VTR.

15 SDI OUT (serial digital interface output) connectors (BNC type)

Output a D-1 format video/audio signal. The same signals are output from the left and right connectors. You can superimpose timecode, menu settings, or error messages on the output of the 2(SUPER) connector when CHARACTER on the HOME page of the function menu is set to ON.

For details on CHARACTER setting, see “3-7 Basic Operations of the Function Menu” on page 29.

16 COMPOSITE OUT (analog composite video output) connectors (BNC type)

Output analog composite video signals. You can superimpose timecodes, menu settings, or error messages on the output of the 2 (SUPER) connector when CHARACTER on the HOME page of the function menu is set to ON.

For details on the CHARACTER setting, see “3-7 Basic Operations of the Function Menu” on page 29.

3-1 Preparing Power Sources

This unit can be powered by AC power, DC power, or a battery pack.

Note

If you load or remove a battery pack incorrectly, it may fall and cause bodily injury. Follow the procedures described below to load or remove them.

3-1-1 Supplying Power

This unit has two power switches, one on the front panel and another on the rear panel. The power switch on the front panel is to turn DC power ON/OFF, and the POWER switch on the rear panel is to turn AC power ON/OFF. Power is supplied to the unit in combination of these two switches as shown below. When AC power is switched on, the AC power indicator lights on the front panel. When DC power is switched on, a battery mark appears in the display window on the front panel.

		Power switch on the front panel	
		I (ON)	⏻ (OFF)
POWER switch on the rear panel	ON	AC power supply AC indicator lit	No power supply AC indicator lit
	OFF	DC power supply AC indicator not lit	No power supply AC indicator not lit

AC power supply

Connect the AC IN connector to an AC power source using the specified AC power cord. To supply AC power to the unit, set the power switch on the front panel to I (ON) and the POWER switch on the rear panel to ON.

DC power supply

Connect the DC IN 12V connector to a DC power source. To supply DC power to the unit, set the power switch on the front panel to I (ON) and the POWER switch on the rear panel to OFF. If the POWER switch on the rear panel is set to ON, AC power is supplied.

Battery power supply

Charge a battery pack beforehand using the BC-L100 Battery Charger. The BP-GL65 is fully charged for about 2.5 hours and the BP-GL95 is fully charged for about 3.5 hours. Using the fully-charged BP-GL95, continuous recording of up to 80 minutes is possible.

For details on charging battery packs, refer to the operation manual for the BC-L100.

Applicable battery packs

Battery packs that can be used with this unit are as follows. To use battery pack, a BKP-L551 Battery Adaptor and a BC-L100 Battery Charger are required.

- BP-L60(A)/L90(A)
- BP-GL65/GL95
- BP-M50/M100

Notes about battery usage

- Before using the batteries, be sure to charge them fully with the special battery charger. Refer to the operating instructions for your battery charger for more information about how to charge the batteries.
- Batteries may not be completely charged if you charge them immediately after use when they are still warm. You should wait until the batteries cool before charging them.

3-1-2 Using the BP-GL65/GL95 Battery Pack

Attaching a battery pack

Attach the BKP-L551 Battery Adaptor to the side panel of this unit and attach the BP-GL65/GL95 Battery Pack in it. The BP-L60(A)/L90(A) and BP-M50/M100 can also be attached in the same way.

For details on attaching the BKP-L551, refer to the installation manual for the BKP-L551.

- 1 Remove the two screws on the side panel.

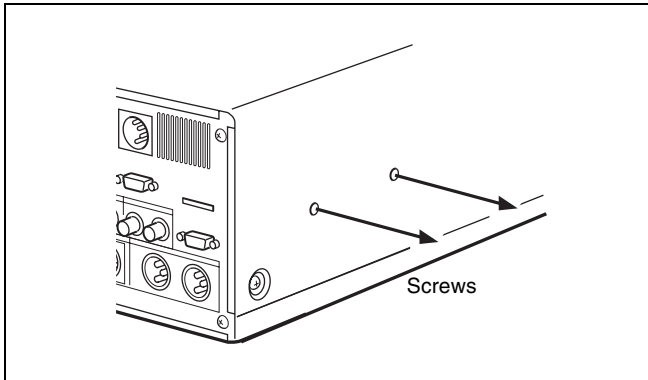

- 2 Attach the BKP-L551 to the side panel.

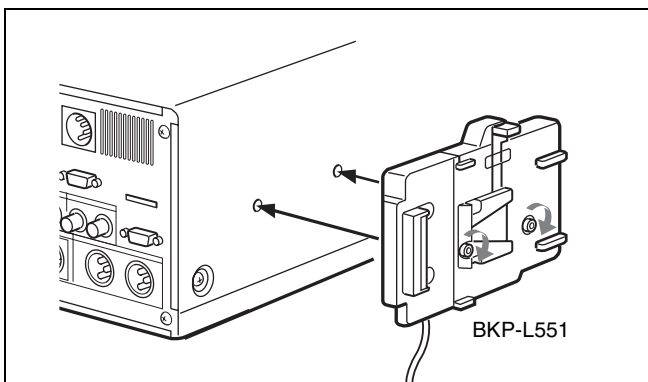

- 3 Align the grooves on the BP-GL65/GL95 with the projections on the BKP-L551.

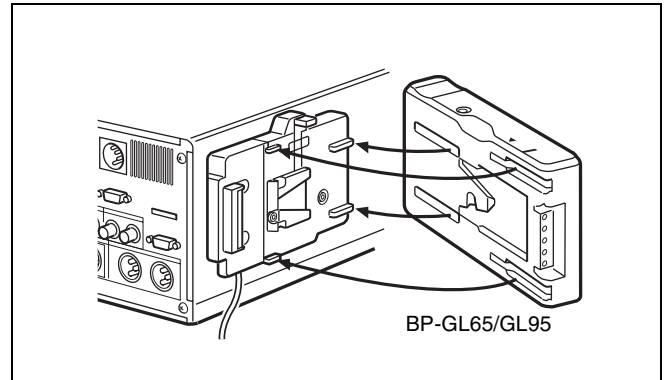

- 4 Slide the BP-GL65/GL95 as shown below so that the connectors on the BP-GL65/GL95 and the BKP-L551 are connected.

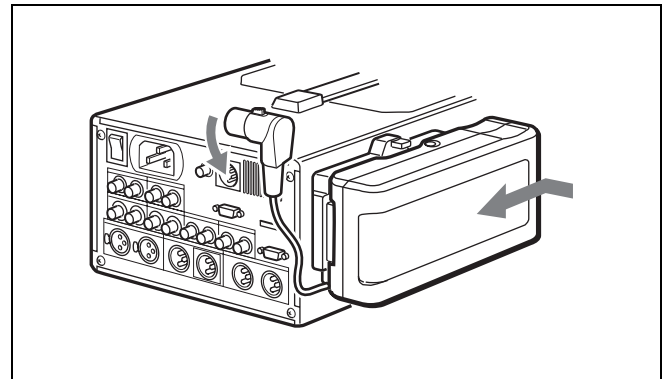

- 5 Connect the DC cable of the BKP-L551 to the DC IN 12V connector.

Removing the battery pack

With the lever pushed in, slide the BP-GL65/GL95 out as shown below.

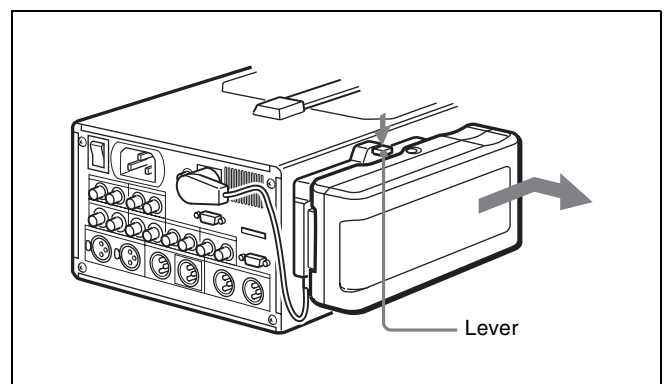

The BP-L60(A)/L90(A) and BP-M50/M100 can also be removed in the same way.

3-2 Using a Stand

Placing the unit using a stand

- 1 Remove the stand from the clamps and turn it, as indicated by the arrow.

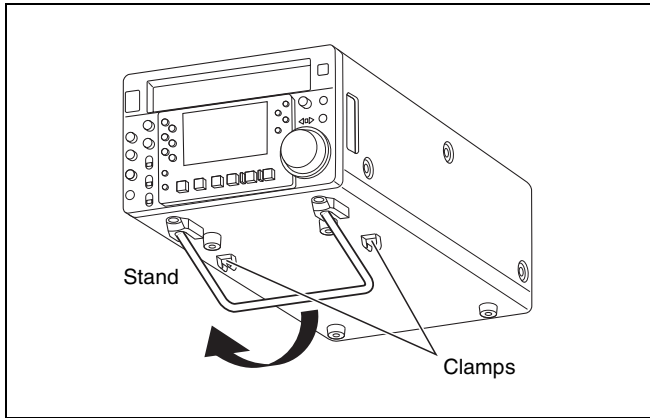

- 2 Push the stand in, as indicated by the arrow.

Be sure to push it to the end.

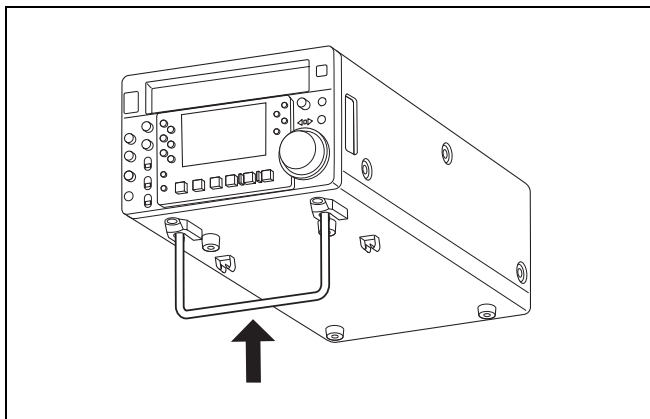

Replacing the stand

Pull the stand out, turn it in the opposite direction of that in step 1 above, and secure it with the clamps.

Note

Never hold the unit with the stand.

3-3 Connections

For editing using two HDW-S280 units, connect them as shown below.

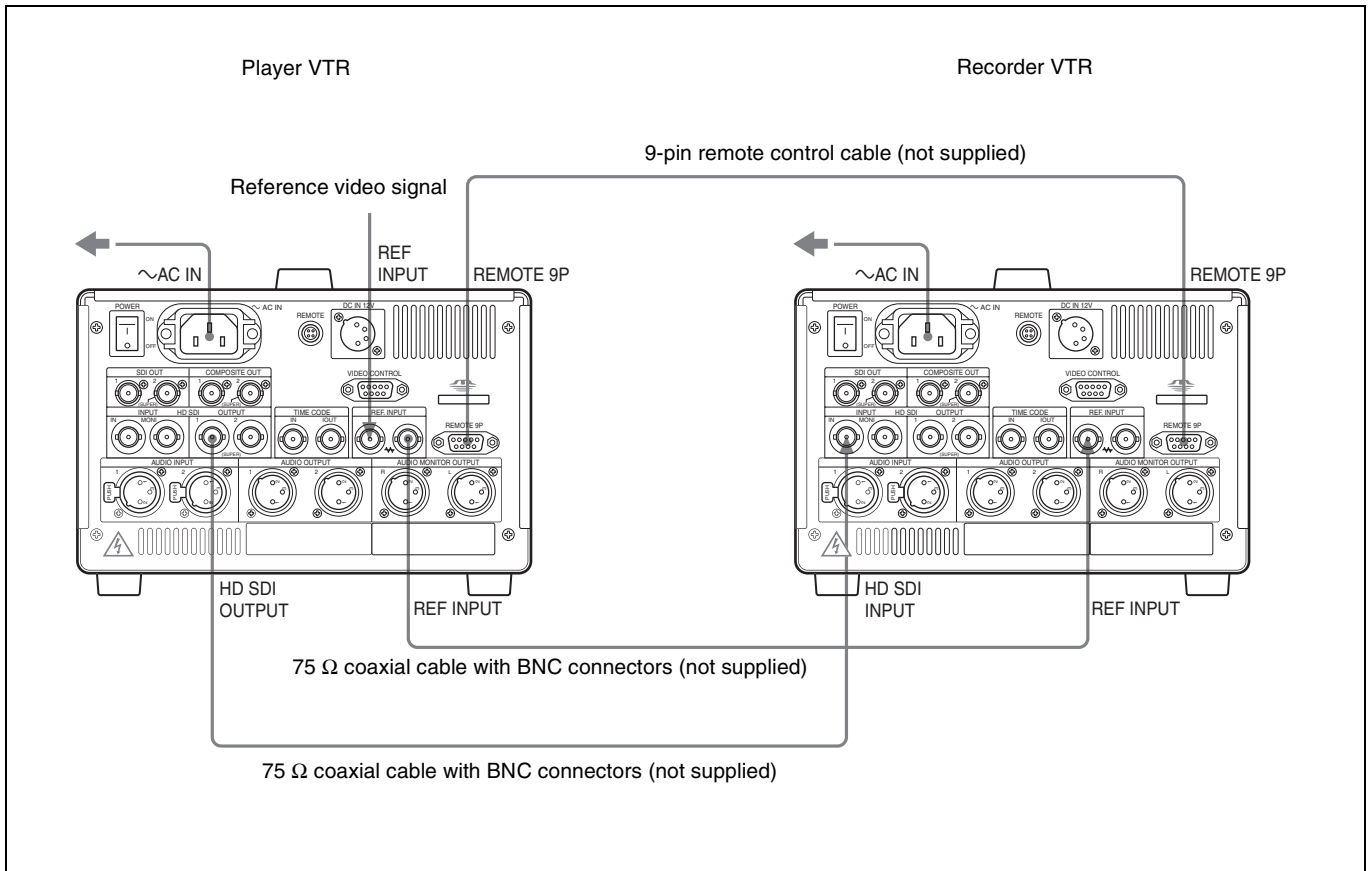

3-4 Handling Cassettes

3-4-1 Usable Cassettes

For recording and playback, you can use an HDCAM S cassette such as a BCT-6HD/12HD/22HD/32HD/40HD. You can use the following cassette, for playback only:

- Betacam SX cassette
- Betacam SP cassette (metal tape)
- Betacam cassette (oxide tape)

3-4-2 Loading/Ejecting Cassettes

Loading a cassette

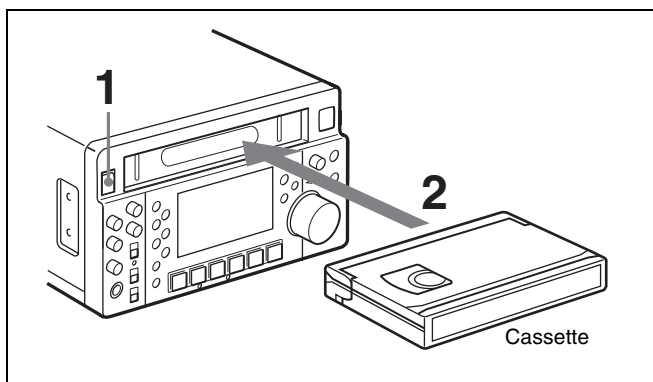

- 1 Supply the power.
- 2 Load a cassette in the direction shown in the figure above after checking the following points.
 - That ERROR-10 is not displayed in the display window.
 - That there is no slack in the tape.

If ERROR-10 appears in the display window

This means that there is condensation inside the unit.

For the steps to take in such a case, see “10-5 Moisture Condensation” on page 81.

If there is slack in the tape

Take up the slack by rotating the reels in the directions indicated by the arrows in the figure, keeping one reel fixed by pressing it with your finger as you rotate the other reel. The reels stop rotating when there is no more slack.

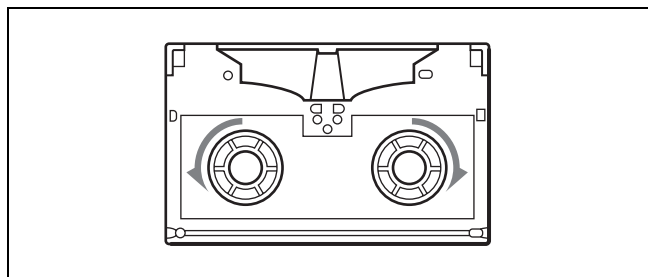

Ejecting the cassette

- 1 With the unit powered on, press the EJECT button. A part of the cassette comes out from the unit.
- 2 Take out the cassette.

3-4-3 Preventing Accidental Erasures

To make it impossible to accidentally erase or record over the contents of a cassette, press in the erasure prevention plug. Return the plug to its original position when you wish to record on the cassette again.

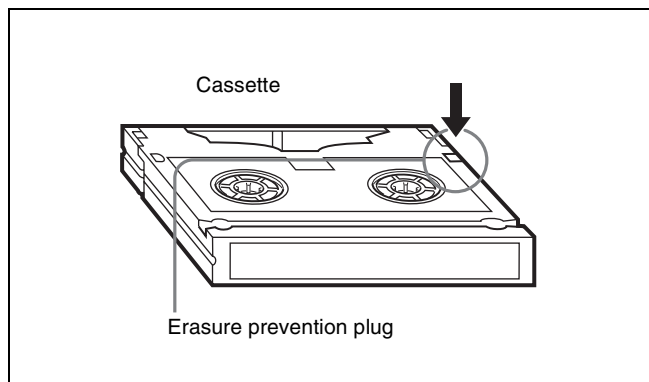

3-5 Setting Reference Video Signals

This section explains how reference video signals for synchronization of video output and servo lock are selected according to settings made with this unit.

Reference video signal for video output

Output video signals are synchronized with the signal generated by the internal reference video signal generator. The internal reference video signal generator can be synchronized with an external reference video signal or with an input video signal (HD SDI input).

Reference video signal for servo lock

Servo is locked with an external reference video signal, an input video signal (HD SDI input), or the signal generated by the internal reference video signal generator. As shown in the following table, a signal for synchronization of the internal reference video signal generator and a reference video signal for servo lock are selected according to the setting for setup menu items 309 and 334, the setting for OUT REF on the P2 VIDEO page of the function menu, and the operating mode of the unit.

For details on setup menu item 309, see page 66, and for item 334, see page 66.

For details on the OUT REF settings, see “3-7 Basic Operations of the Function Menu” on page 29.

OUT REF setting	Item 309 setting	Item 334 setting	Operation mode	Reference signal		
--	EXT	NORMAL	EE	REF		
			PB			
			ASSEMBLE			
			REC			
		INPUT	EE	IPUT		
			PB			
			ASSEMBLE			
			REC			
REF	AUTO1	NORMAL	EE	REF		
			PB			
			ASSEMBLE			
			REC			
		INPUT	EE	INPUT		
			PB			
			ASSEMBLE			
			REC			
INPUT	--	--	EE	REF		
			PB			
			ASSEMBLE			
			REC			
		REF	AUTO2	NORMAL	EE	REF
					PB	
					ASSEMBLE	
					REC	
INPUT	EE			INPUT		
	PB					
	ASSEMBLE					
	REC					
INPUT	--	--	EE	REF		
			PB			
			ASSEMBLE			
			REC			

EE: E-E mode
 PB: Playback (Normal playback, jog mode, shuttle mode, stop mode)
 ASSEMBLE: Assemble edit mode (ASSEMBLE on the HOME page of the function menu is set to ON.)
 REC: Recording

If the signal selected on the menu is not being input

The servo reference video signal and internal reference signal generator synchronize as follows.

When INPUT is selected for the sync signal

If a video signal is not being input, the servo reference video signal and internal reference signal generator synchronize with an external reference video signal.

When REF is selected for the sync signal

If an external reference video signal is not being input, the unit does not synchronize with an external sync signal. The servo reference signal synchronizes with the output of the reference video signal generator.

3-6 Setting Timecode

There are three ways to record timecodes. You can select the recording method with TCG (INT/EXT/SDI) and PRST/RGN (PRESET/LTC/VITC) on the P4 TC page of the function menu.

Recording method	TCG setting	PRST/RGN setting
Record the output of the internal timecode generator with the initial value set.	INT	PRESET
Record the output of the internal timecode generator synchronized with the external timecode generator.	EXT or SDI	LTC or VITC
Record the output of the internal timecode generator synchronized with the playback timecode. (During editing, this method is always used.)	INT	LTC or VITC

Settings for RUN (REC/FREE) and DF (DF/NDF) on the P4 TC page of the function menu are required in addition to the settings for TCG and PRST/RGN.

For details on settings on the function menu, see “3-7 Basic Operations of the Function Menu” on page 29.

3-6-1 Setting an Initial Value and Recording Timecode

For setting the timecode, set TCG on the P4 TC page of the function menu to INT and PRST/RGN to PRESET.

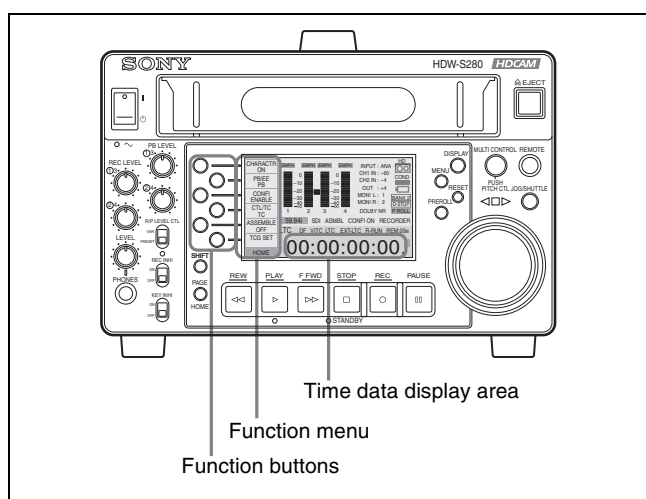

Setting an initial timecode value

Proceed as follows:

- 1 Press the CTL/TC function button on the HOME page of the function menu, and select TC.
- 2 Press the TCG SET function button.

The first digit of the time data in the time data display area starts flashing.

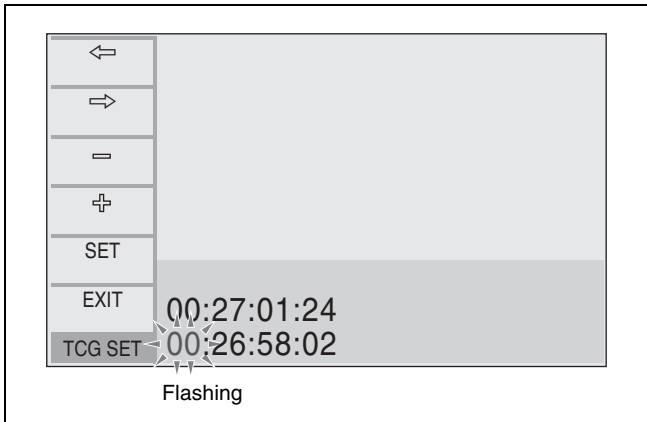

- 3 Press the ← or → function button to select a digit to be set.
The selected digit starts flashing.
- 4 Press the – or + function button to set the value for the selected digit.
Repeat steps 3 and 4 to set all digits that should be set.
- 5 Press the SET function button.
If RUN on the P4 TC page is set to FREE, the timecode starts running.

To cancel a setting

Press the EXIT function button. Any new settings to that point are canceled, and the setting operation is terminated.

Setting the timecode to the current time

- 1 Set RUN on the P4 TC page to FREE and DF to DF (in 59.94i mode only).
- 2 Perform steps 1 to 4 of “Setting an initial timecode value” to set the timecode to a time slightly ahead of the current time.
- 3 Press the SET function button at the instant when the current time matches the displayed timecode.

Setting user bits

You can record up to 8 hexadecimal digits of information (date, time, event number, etc.) on the timecode track. Select UB by pressing the CTL/TC function button in step 1 of “Setting an initial timecode value” and Carry out steps 2 to 5. Settings are made in hexadecimal (0-9, A-F). You can record ID codes in user bits.

For details, see setup menu items 603 and 604 on page 68.

3-6-2 Synchronizing the Internal Timecode Generator with an External Signal

Use this method to synchronize multiple VTRs with an external timecode generator, and when you wish to record the playback timecode signals of an external VTR without deterioration in the signal waveform.

You can synchronize the internal timecode generator with either of the following kinds of external timecode.

- The output of an external timecode generator or the timecode output (LTC) of an external VTR
- The timecode (LTC or VITC) in an input video signal

Proceed as follows:

- 1 **To synchronize with external timecode output (LTC):**
Connect a cable between the output of an external timecode generator or the timecode output of an external VTR to the TIME CODE IN connector.

To synchronize with the timecode (LTC or VITC) of an input video signal:
Set VIDEO IN on the P2 VIDEO page of the function menu to SDI.
- 2 Set the followings of the function menu:
TCG on the P4 TC page: EXT or SDI
PRST/RGN on the P4 TC page: LTC or VITC

The internal timecode generator begins to run in synchronization with the external signal. Once external synchronization is achieved, the internal timecode generator continues to run even if you disconnect the external timecode generator.

3-6-3 Synchronizing the Internal Timecode Generator with a Playback Timecode – Timecode Recording during Auto Editing

Set the following on the function menu:

TCG on the P4 TC page: INT

PRST/RGN on the P4 TC page: LTC or VITC

In automatic editing, timecodes are recorded by using the output of the internal timecode generator, which has been synchronized during preroll with playback timecode read from the tape. For this reason, regardless of the actual settings of TCG and PRST/RGN on the P4 TC page, the unit operates as if then were set to INT and LTC or VITC. If you do not wish to have TCG and PRST/RGN settings fixed during automatic editing, you can set them with setup menu item 610.

For details on setup menu item 610, see page 69.

If you set TCG on the P4 TC page to EXT or SDI and PRST/RGN to PRESET, PRST/RGN is forced to function as LTC.

3-6-4 Converting Timecode in 24- or 25-Frame Mode Playback (TC CONV)

When a tape recorded in 24-frame mode is played back in 25-frame mode (off-speed playback), the timecodes for 24-frame mode can be converted to those for 25-frame mode. It is also possible to have the timecodes recorded in 25-frame mode converted to those for 24-frame mode during playback. To have the timecodes converted, set setup item 620 to ON.

For details on setup menu item 620, see page 69.

Note

While the timecodes are being converted, the timecode generator generates timecodes based on the frame frequency recorded on the tape, which makes a difference in the timecodes generated in FREE RUN of about 4%.

3-7 Basic Operations of the Function Menu

The function menu is composed of eight pages: the HOME page and P1 to P7 pages. The content of the HOME page and P1 to P6 pages is as shown below. The P7 page can be set with the setup menu as desired.

For details on settings on the P7 page, refer to the maintenance manual.

3-7-1 Configuration of the Function Menu

	HOME	P1 PROCS	P2 VIDEO	P3 AUDIO	P4 TC	P5 EDIT	P6 OTHER
F1	CHARACTR	VID.PROC	VIDEO IN	AUDIO IN	TCG	R/P	UMID
	ON/OFF	LOCAL/MENU	SDI/SG	ANALOG/ SDI/SG	INT/EXT/ SDI	RECORDER/ PLAYER	
F2	PB/EE	VIDEO	OUT REF	MONITR L	PRST/RGN	IN	STOPCODE
	PB/EE	PRESET/XXXX	REF/INPUT	CH1/CH2/CH3/ CH4/CUE	PRESET/LTC/ VITC	Not displayed/ Lit/Flashing ^{a)}	
F3	CONFI	CHROMA	--	MONITR R	RUN	DELETE	--
	ENABLE/ DISABLE	PRESET/XXXX		CH1/CH2/CH3/ CH4/CUE	FREE/REC	Not displayed/ Lit/Flashing ^{a)}	
F4	CTL/TC	HUE/CHRM PHS	--	LEVEL MT	DF	OUT	--
	TC/UB/CTL	PRESET/XXXX		LEFT/RIGHT/ LEFT(4)/ RIGHT(4)/OFF	DF/NDF	Not displayed/ Lit/Flashing ^{a)}	
F5	ASSEMBLE	SETUP/BLACK	SYNC	EMPHASIS	--	PREVIEW/ REVIEW	--
	ON/OFF	PRESET/XXXX	0	ON/OFF		Not displayed/ PREVIEW/ REVIEW ^{a)}	
F6	TCG SET	Y/C DELY	SC	DOLBY NR	TCR	AUTOEDIT	--
		PRESET/XXXX	0	ON/OFF	LTC/AUTO/VITC	Not displayed/ Lit/Flashing ^{a)}	

a) An indicator appears according to the status of the unit, and lights or flashes.

3-7-2 Function Menu Item List

HOME page

Item	Setting
CHARACTR	Specifies whether or not to superimpose timecodes, menu settings, error messages, and so on over the video signals output to the HD SDI OUTPUT (SUPER) connectors, SDI OUT 2 (SUPER) connector, and COMPOSITE OUT 2 (SUPER) connector. ON: Superimpose. OFF: Do not superimpose.
PB/EE	Selects the video and audio signals output during fast forward, rewind, stop, and standby. PB: Playback signals EE: E-E mode signals
CONFI	Selects whether or not to use the confidential playback function when recording. ENABLE: Use the confidential playback function. DISABLE: Do not use the confidential playback function.
CTL/TC	Selects the time data to display in time data display area. TC: Playback timecode read by the internal timecode reader or recording timecode. The LTC or VITC time data type indicator is lit. ^{a)} UB: User bits data of playback timecodes or recording timecode. The LUB or VIUB time data type indicator lights, depending on whether the timecode is LTC or VITC. ^{a)} CTL: The running time of the tape being played back or recorded, as calculated from a count of CTL signals recorded on the tape. The time is displayed in Hours:Minutes:Seconds:Frames format.
ASSEMBLE	Sets assemble edit mode. ON: The assemble edit mode is set, and ASMBL appears in the display window. OFF: The assemble edit mode is canceled.
TCG SET	When CTL/TC is set to TC, a screen for setting the initial value of the timecode generated by the internal timecode generator appears. ^{b)} When CTL/TC is set to UB, a screen for setting the user bit of the timecode appears. ^{b)}

Item	Setting
Submenu	
←/→	Selects the digit to set data.
-/+	Sets the value.
SET	Stores the set timecode.
EXIT	Terminates the operation, abandoning any settings not registered.

- a) The selection of LTC and VITC depends on the setting for TCR on the P4 TC page.
b) Not displayed when TCG is not set to INT and PRST/RGN is not set to PRESET on the P4 TC page.

P1 PROCS page

Item	Setting
VID.PROC	Selects the control method for the internal digital video processor. LOCAL: Change the settings of the internal digital video processor by using the function menu. MENU: Change the settings of the internal digital video processor, using the setup menu. Note When controlling the unit with the HKDV-900, set to MENU.
VIDEO	Sets the HD/SD video signal output level ($-\infty$ to +3 dB). PRESET: Regardless of manually set values, the video signal is set to the standard level. Manual setting: With the displayed setting flashing, you can adjust the video signal output level by rotating the MULTI CONTROL knob.
CHROMA	Sets the HD/SD chroma signal output level ($-\infty$ to +3 dB). PRESET: Regardless of manually set values, the chroma signal is set to the standard level. Manual setting: With the displayed setting flashing, you can adjust the chroma signal output level by rotating the MULTI CONTROL knob.
HUE/CHRM PHS	Sets the color phase of the HD/SD output signal. PRESET: Regardless of manually set values, the color phase is set to the standard value. Manual setting: With the displayed setting flashing, you can adjust the value across the range $\pm 30^\circ$ by rotating the MULTI CONTROL knob.

Item	Setting
SETUP/ BLACK	Sets the setup level (59.94i mode) or black level (50i mode) of the HD/SD output signal. PRESET: Regardless of manually set values, the level is set to the standard value. Manual setting: With the displayed setting flashing, you can adjust the setup level across the range ± 30 IRE (59.94i mode) or adjust the black level across the range ± 210 mV (50i mode) by rotating the MULTI CONTROL knob.
Y/C DELY	Sets the Y/C delay during playback of an analog Betacam cassette. PRESET: Regardless of manually set values, the Y/C delay is set to the standard value. Manual setting: With the displayed setting flashing, you can adjust the Y/C delay across the range ± 100 ns by rotating the MULTI CONTROL knob.

P2 VIDEO page

Item	Setting
VIDEO IN	Selects the input video signal. SDI: HD SDI signal SG: Test signal generated by the internal test signal generator (To select SG, hold the corresponding function button pressed for more than three seconds.)
OUT REF	Selects the reference signal of this unit, according to the settings of setup menu items 309 and 334, and the operating state of this unit. REF: Use the signal input to the REF INPUT connector as the reference signal. During recording, input digital audio signals and video signals must be synchronized with this signal. INPUT: Use the input video signal as the reference signal.
SYNC	Sets the SD/HD output signal sync phase. Setting method Press the SYNC function button then rotate the MULTI CONTROL knob to adjust the output signal sync phase with the displayed setting flashing. The adjustable range is ± 15 μ s relative to the input reference signal. Adjust this item if you wish to adjust the output signal sync phase precisely to match a reference signal or when connecting this unit and other VTRs to a device such as a switcher to perform operations such as special effects editing.

Item	Setting
SC	Sets the SD/HD output signal subcarrier phase. Setting method Press the SC function button then rotate the MULTI CONTROL knob to adjust the output signal subcarrier phase with the displayed setting flashing. The adjustable range is ± 200 ns relative to the input reference signal. Adjust this item when you are using composite signals in editing and wish to adjust the output signal subcarrier phase precisely to match a reference signal. Even when this value is adjusted, the output SCH (subcarrier to sync) phase is maintained.

P3 AUDIO page

Item	Setting
AUDIO IN	Selects an audio input signal. The selected signal is shown at INPUT in the audio data area. ANALOG: Analog audio signal SDI: SDI signal SG: SG signal
MONITR L	Selects an output signal from the AUDIO MONITOR OUTPUT L connector (CH1/CH2/CH3/CH4/CUE). The selected signal is shown at MONI L in the audio data area.
MONITR R	Selects an output signal from the AUDIO MONITOR OUTPUT R connector (CH1/CH2/CH3/CH4/CUE). The selected signal is shown at MONI R in the audio data area.
LEVEL MT	Sets the audio level meter displayed on the video monitor display. LEFT: Display the audio level meter on the left of the video monitor display. RIGHT: Display the audio level meter on the right of the video monitor display. LEFT (4): Displays the four-channel audio level meters on the left of the video monitor display. RIGHT (4): Displays the four-channel audio level meters on the right of the video monitor display. OFF: Not display the audio level meter.
EMPHASIS	Specifies whether to add audio emphasis to analog audio input signals and Betacam/Betacam SP format playback audio signals. ON: Add audio emphasis. OFF: Do not add audio emphasis.
DOLBY NR	When using oxide tapes, this is to specify whether or not to use the Dolby type C low-frequency noise reduction (NR) system. ON: Use the Dolby NR system when playing back analog Betacam oxide tapes. OFF: Do not use the Dolby NR system when playing back analog Betacam oxide tapes.

P4 TC page

Item	Setting
TCG	<p>Selects the signal source to which the internal timecode generator synchronizes. The selected timecode appears in the timecode setup area.</p> <p>INT: Synchronize according to the initial preset value set by front panel operation or by remote control from the device connected to the REMOTE 9P connector, or synchronize to the timecode of the playback tape.</p> <p>EXT: Synchronize to the timecode signal input via the TIME CODE IN connector.</p> <p>SDI: Synchronize to the timecode data superimposed on the HD SDI signal input to the HD SDI INPUT connector.</p>
PRST/RGN	<p>Selects one of the following for timecodes generated by the internal timecode generator.</p> <p>PRESET: Presets the initial value for the timecode generated by the internal timecode generator, as specified by front panel operation or by remote control from the device connected to the REMOTE 9P connector. This operation is enabled when TCG is set to INT. At other times, the operation is the same as when LTC is selected.</p> <p>LTC: Regenerate timecodes by synchronizing with the LTC timecode value read by the internal timecode reader.</p> <p>VITC: Regenerate timecodes by synchronizing with the VITC timecode value read by the internal timecode reader. If TCG is set to EXT, the operation is the same as SDI.</p>
RUN	<p>Selects one of the following running modes for the internal timecode generator.</p> <p>FREE: The timecode continues to increase as long as the unit is powered on, regardless of the operating mode of this unit.</p> <p>REC: The timecode increases during recording only. If you select this mode, you should also set TCG to INT, and set PRST/RGN to PRESET.</p>
DF	<p>In 59.94i mode, this is to select either drop-frame mode or non drop frame mode for the timecode generator and the CTL counter.</p> <p>DF: Drop frame mode</p> <p>NDF: Non-drop frame mode</p>
TCR	<p>Selects the type of timecode to display in the time data display area.</p> <p>LTC: Display LTC.</p> <p>AUTO: Display VITC when the tape speed is 0.5 or less normal speed, and LTC otherwise.</p> <p>VITC: Display VITC.</p>

P5 EDIT page

Item	Setting
R/P	<p>Selects which VTR to be controlled (player or recorder) when two VTRs are connected, the VTR connected to the REMOTE 9P connector is used as a player and this unit is used as a recorder. (For a single VTR operation, press the button for more than two seconds.)</p> <p>RECORDER: Controls this unit (the recorder VTR).</p> <p>PLAYER: Controls the connected player VTR.</p>
IN	<p>Sets the current tape point as the IN point when pressed together with the SHIFT button. An indicator (white bar) appears below the IN display. If only the IN function button is pressed, the time data for the IN point appears in the time data display area.</p>
DELETE	<p>Deletes the set edit point. If the button is pressed together with the IN function button, the IN point is deleted, and if it is pressed together with the OUT function button, the OUT point is deleted. If the set edit points are not correct, the indicator below the DELETE display flashes.</p>
OUT	<p>Sets the current tape point as the OUT point when pressed together with the SHIFT button. An indicator (white bar) appears below the OUT display. If only the OUT function button is pressed, the time data for the OUT point appears in the time data display area.</p>
PREVIEW/REVIEW	<p>Either PREVIEW or REVIEW appears according to the editing status. When the corresponding function is executable, the indicator flashes. If you press this button together with the SHIFT button, the corresponding function will be performed. During preview or review the indicator is lit, and when finished the indicator returns to flashing.</p>
AUTOEDIT	<p>If you press this button together with the SHIFT button while the indicator is flashing, automatic editing will be performed. During automatic editing the indicator is lit, and when it is finished, the indicator starts flashing again.</p>

UMID	Displays UMID information during recording/playback.
STOPCODE	Displays the STOPCODE submenu page.
Submenu	
DETECT	Specifies the operation mode when a stop code is detected during playback. ON: Recording/playback stop when a stop code is detected. When set to ON, D-STOP appears in the condition area. OFF: Recording/playback does not stop when a stop code is detected.
REC/ERAS	Records or erases a stop code. OFF: Stop code not to be recorded or erased. REC: Stop code to be recorded. ERASE: Stop code to be erased.
REC	Records a stop code if you press this button together with the SHIFT button when REC/ERAS is set to REC.
ERASE	Erases a stop code by pressing this button together with the SHIFT button when REC/ERAS is set to ERASE.
CHECK	Checks a recorded stop code if you press this button together with the SHIFT button after recording a stop code.
EXIT	Returns to the P6 OTHER page.

3-7-3 Basic Operations

This section describes the basic operations of the function menu. Operation of some items may differ from the basic ones, which are described in the corresponding sections.

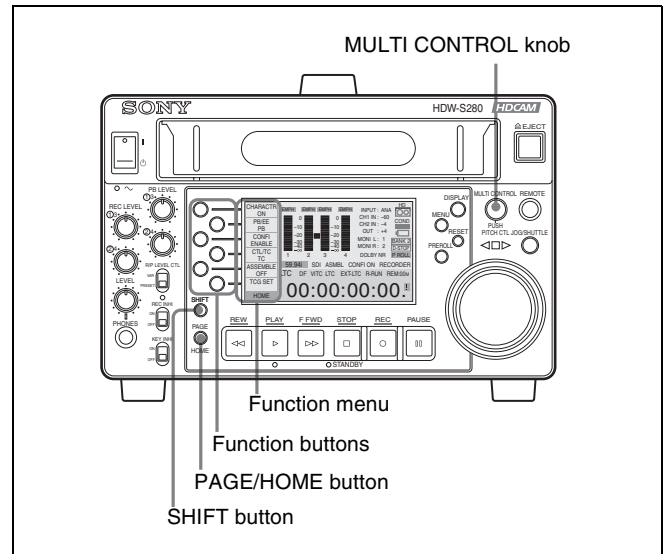

1 Press the PAGE button to display the menu page to be set.

You can change the displayed page by rotating the MULTI CONTROL knob while holding the PAGE button holding pressed.

2 Press the corresponding function button to select an item to be set.

3 Set the selected items by the following methods:

- Press the corresponding function button to display the content to be set.
- Rotate the MULTI CONTROL knob to adjust a displayed value.

To return to the HOME page

Press the PAGE/HOME button together with the SHIFT button.

3-8 Superimposed Character Information

When CHARACTER on the HOME page of the function menu is set to ON, the video signal output from the HD SDI OUTPUT (SUPER) connectors, SDI OUT 2 (SUPER) connector, or COMPOSITE OUT 2 (SUPER) connector contains superimposed character information, including timecodes, menu settings, and alarm messages.

Adjusting the character display

You can adjust the position, size, and type of the superimposed characters using setup menu items 002, 003, 005, 009, 011, and 012.

For details on setup menu items 002, 003, 005, 009, 011, and 012, see page 61 and page 62.

Information displayed

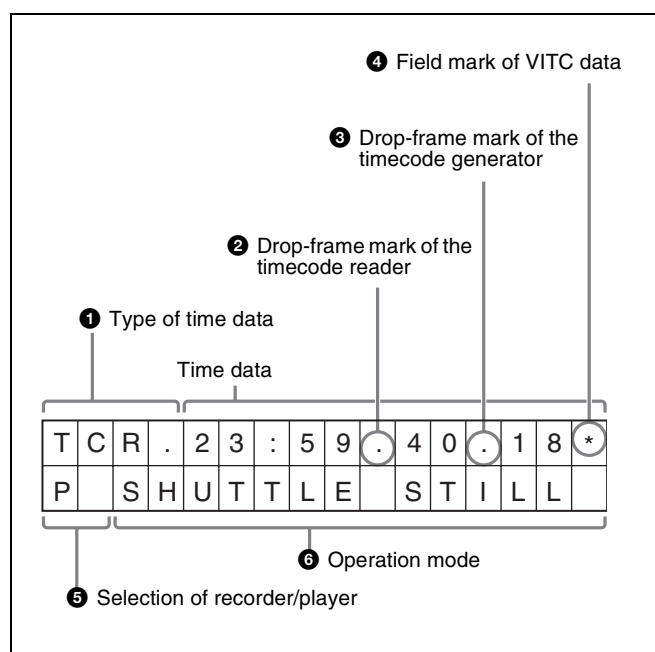

Note

The display shown above corresponds to the factory default settings of the unit. Changing the setting of setup menu item 005 allows different time data to be displayed on the lower line of the display.

For details on setup menu item 005, see page 61.

1 Type of time data

Display	Meaning
CTL	Data of the CTL counter
TCR	Timecode read by the LTC reader
UBR	User's bit read by the LTC reader
TCR.	Timecode read by the VITC reader
UBR.	User's bit read by the VITC reader
TCG	Timecode generated by the timecode generator
UBG	User's bit generated by the timecode generator
IN	IN point
OUT	OUT point
DUR	Duration between the IN and OUT points

Note

If the time data or user's bits cannot be read correctly, each item in question will be displayed with an asterisk. Example: T*R, U*R, T*R. or U*R.

2 Drop frame mark of the timecode reader (for 59.94i mode only)

“.”: Indicates drop frame mode

“:” : Indicates non-drop-frame mode

3 Drop frame mark of the timecode generator (for 59.94i mode only)

“.”: Indicates drop frame mode (factory preset)

“:” : Indicates non-drop-frame mode

4 Field mark of VITC data

(blank): Fields 1 and 3 (for 59.94i mode) or fields 1, 3, 5 and 7 (for 50i mode)

“*”: Fields 2 and 4 (for 59.94i mode) or fields 2, 4, 6 and 8 (for 50i mode)

5 Selection of recorder/player

The indication changes as follows, according to the setting for R/P on the P5 EDIT page of the function menu:

P: PLAYER is selected.

R: RECORDER is selected.

6 Operation mode

The field is divided into three blocks: A, B and C.

Block A: Displays the operation mode.

Block B: Displays the servo lock status or tape speed.

Block C: Displays a ■ mark to indicate an edit section during automatic editing.

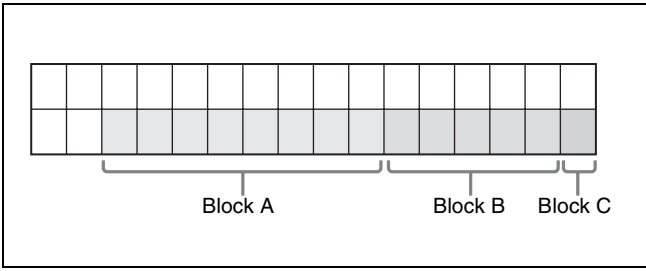

Display		Operation mode
Block A	Block B	
TAPE UNTHREAD		No cassette inserted
STANDBY OFF		Standby off mode
T.RELEASE		Tape tension release mode
STOP		Stop mode
F.FWD		Fast forward mode
REW		Rewind mode
PREROLL		Preroll mode
PLAY		Play mode (servo unlocked)
PLAY	LOCK	Play mode (servo locked)
PLAY	PAUSE	Play mode (standby)
REC		Record mode (servo unlocked)
REC	LOCK	Record mode (servo locked)
REC	PAUSE	Record mode (standby)
JOG	STILL	Still picture in jog mode
JOG	FWD	Jog in forward direction
JOG	REV	Jog in reverse direction
SHUTTLE	(speed)	Shuttle mode
AUTOEDIT		Automatic editing mode
PREVIEW		Preview mode
REVIEW		Review mode
SEQ-REC		Sequential record mode (serve unlocked)
SEQ-REC	LOCK	Sequential record mode (serve locked)

3-9 Using a "Memory Stick"

When a "Memory Stick" is inserted in the camera, the file data can be stored on the "Memory Stick," which enables you to share data among cameras.

Inserting a "Memory Stick"

Insert a "Memory Stick" with the label side up into the "Memory Stick" slot until it clicks.

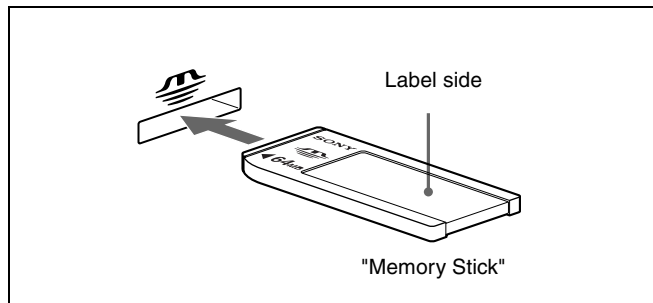

To remove a "Memory Stick"

If you push the inserted "Memory Stick," the "Memory Stick" will pop out a little. Then pull the "Memory Stick" out.

Precautions

- To prevent data loss, make backups of data frequently. In no event will Sony be liable for any loss of data.
- Unauthorized recording may be contrary to the provisions of copyright law. When you use a "Memory Stick" that has been pre-recorded, be sure that the material has been recorded in accordance with copyright and other applicable laws.
- The "Memory Stick" application software may be modified or changed by Sony without prior notice.

3-9-1 Notes on "Memory Stick"

What is "Memory Stick"?

"Memory Stick" is a new compact, portable and versatile IC (Integrated Circuit) recording medium with a data capacity that exceeds that of a floppy disk. "Memory Stick" is specially designed for exchanging and sharing digital data among "Memory Stick"-compatible products. Because it is removable, "Memory Stick" can also be used for external data storage.

"Memory Stick" is available in two sizes: standard size and compact "Memory Stick Duo" size. Once attached to a "Memory Stick Duo" adapter, "Memory Stick Duo" is to the same size as standard "Memory Stick" and thus can be used with products compliant with standard "Memory Stick."

Types of "Memory Stick"

"Memory Stick" is available in the following six types to meet various functional requirements.

"Memory Stick"

Stores any type of data except copyright-protected data that require MagicGate copyright protection technology.

"Memory Stick (MagicGate/High-Speed Transfer Compatible)"

Equipped with MagicGate copyright protection technology and allows high-speed data transfer.

This type of "Memory Stick" can be used with "Memory Stick"-compliant, "MagicGate Memory Stick"-compliant, and "Memory Stick PRO"-compliant products.¹⁾

The HDW-S280 is not compliant with high-speed data transfer with this type of "Memory Stick."

1) Operation is not guaranteed for all of the compliant products (Some products may not accept this type of "Memory Stick.")

"MagicGate Memory Stick"

Equipped with MagicGate copyright protection technology.

"Memory Stick-ROM"

Stores prerecorded, read-only data. You cannot record on "Memory Stick-ROM" or erase the prerecorded data.

"Memory Stick (with Memory Select Function)"

Composed of multiple 128 MB memory units.

The mechanical switch at the back of the "Memory Stick" allows you to select the memory unit to be used depending on usage.

The memory units cannot be used simultaneously and continuously.

"Memory Stick PRO"

"Memory Stick" with MagicGate copyright protection technology, exclusive for "Memory Stick PRO"-compliant products.

This type of “Memory Stick” cannot be used with the HDW-S280 series.

Available types of “Memory Stick”

You can use a “Memory Stick” with the HDW-S280 (8, 16, 32, 64 and 128 MB compatible).

Note

You can not use a “Memory Stick Duo” alone with the HDW-S280. To use a “Memory Stick Duo” with this camera, be sure to attach it to an optional Memory Stick Duo Adaptor. If you insert a “Memory Stick Duo” without the adaptor, it may become stuck in the slot and impossible to remove.

Note on data read/write speed

Data read/write speed may vary depending on the combination of the “Memory Stick” and “Memory Stick” compliant product you use.

What is MagicGate?

MagicGate is copyright protection technology that uses encryption technology.

Before using a "Memory Stick"

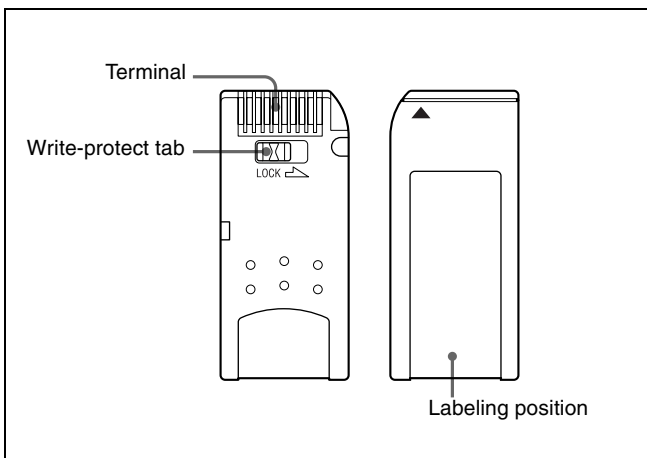

- You cannot record or erase data when the write-protect tab on the “Memory Stick” is set to LOCK.
- We recommend backing up important data.
- Image data may be damaged in the following cases:
 - If you remove the “Memory Stick,” or turn the power off when the access lamp is lit or flashing
 - If you use a “Memory Stick” near static electricity or a magnetic field

Notes

- Do not attach anything other than the supplied label to the “Memory Stick” labelling position.
- Attach the label so that it does not stick out beyond the labelling position.
- Carry and store the “Memory Stick” in its case.

- Do not touch the connector of the “Memory Stick” with anything, including your finger or metallic objects.
- Do not strike, bend, or drop the “Memory Stick.”
- Do not disassemble or modify the “Memory Stick.”
- Do not allow the “Memory Stick” to get wet.
- Do not use or store the “Memory Stick” in a location that is:
 - Extremely hot, such as in a car parked in the sun
 - Under direct sunlight
 - Very humid or subject to corrosive substances

4-1 Recording

This section describes recording for external input signals.

Note

When two HDW-S280 units are connected, press the REMOTE buttons on both VTRs so that they are not lit.

4-1-1 Preparations for Recording

Perform the following procedure:

- 1 Connect a cable to receive the source signals.
- 2 Select which video and audio signals you wish to record on the function menu.

Video: Set VIDEO IN on the P2 VIDEO page to SDI.

Audio: Set AUDIO IN on the P3 AUDIO page to SDI or ANALOG.

For details on the function menu, see “3-7 Basic Operations of the Function Menu” on page 29.

- 3 Select the reference video signals to be used.

For details on setting the reference video signals, see “3-5 Setting Reference Video Signals” on page 25.

- 4 Set the timecode.

For details on setting the timecode, see “3-6 Setting Timecode” on page 26.

Adjusting audio input level

Set the R/P LEVEL CTL switch to VAR and rotate the REC LEVEL adjustment knobs, monitoring the input levels indicated by the audio level meter. You can set the

channels to be controlled with the REC LEVEL adjustment knobs with setup menu item 826.

For details on setup menu item 826, see page 74.

4-1-2 Recording Operation

Confirm that the REC INHI indicator on the front panel is not lit. Then, follow the procedure below.

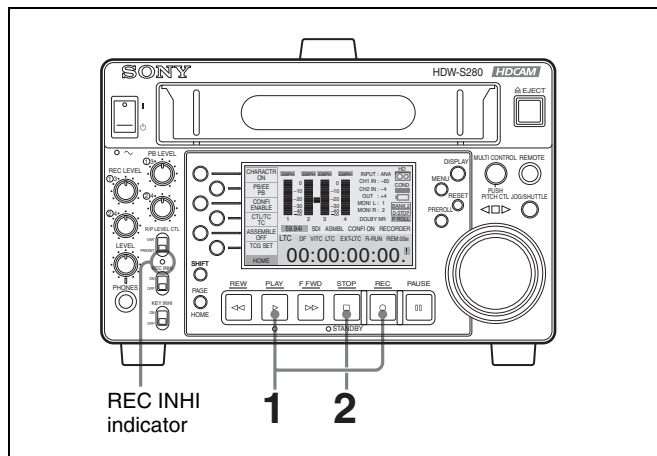

- 1 Press the REC and PLAY buttons simultaneously. Recording begins.

- 2 Press the STOP button to stop recording.

If recording continues to the end of the tape, the tape automatically rewinds to the beginning and stops.

4-2 Back Space Editing

You can record multiple scenes as a single sequence with no noise or breakup between scenes (back space editing). Proceed as follows.

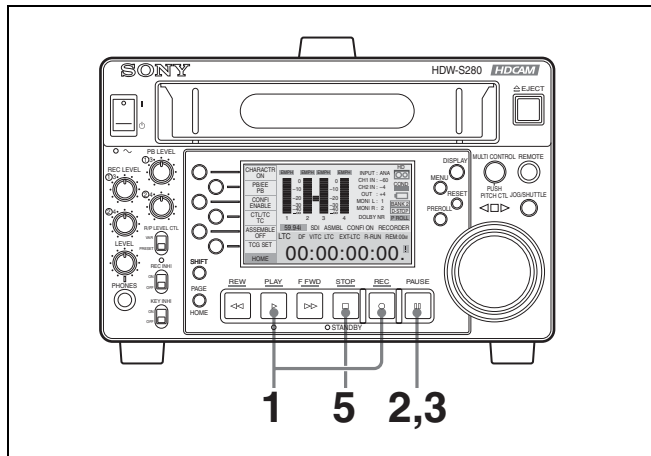

- 1 Press the REC button and PLAY button simultaneously.
Recording begins.
 - 2 When recording finishes, press the PAUSE button.
The tape is rewound a little to a point just before where it was when you pressed the PAUSE button, and the unit enters recording pause mode.
- Note**
When recording is paused, do not do any of the following (if you do, back space editing will be interrupted):
- Eject a cassette.
 - Play back, rewind, or fast forward the tape.
 - Press the STOP button.
- 3 At the next scene, press the PAUSE button.
The tape moves to the recording start position, and recording starts.
 - 4 Repeat steps 2 and 3 to record more scenes.
 - 5 When you are finished recording scenes, press the STOP button.

Recording continuous timecode

Set setup menu item 610 to a setting other than MANU.

For details on setup menu item 610, see page 69.

4-3 Sequential Recording

When you connect two HDW-S280 units as shown below, you can perform sequential recording from one unit to another.

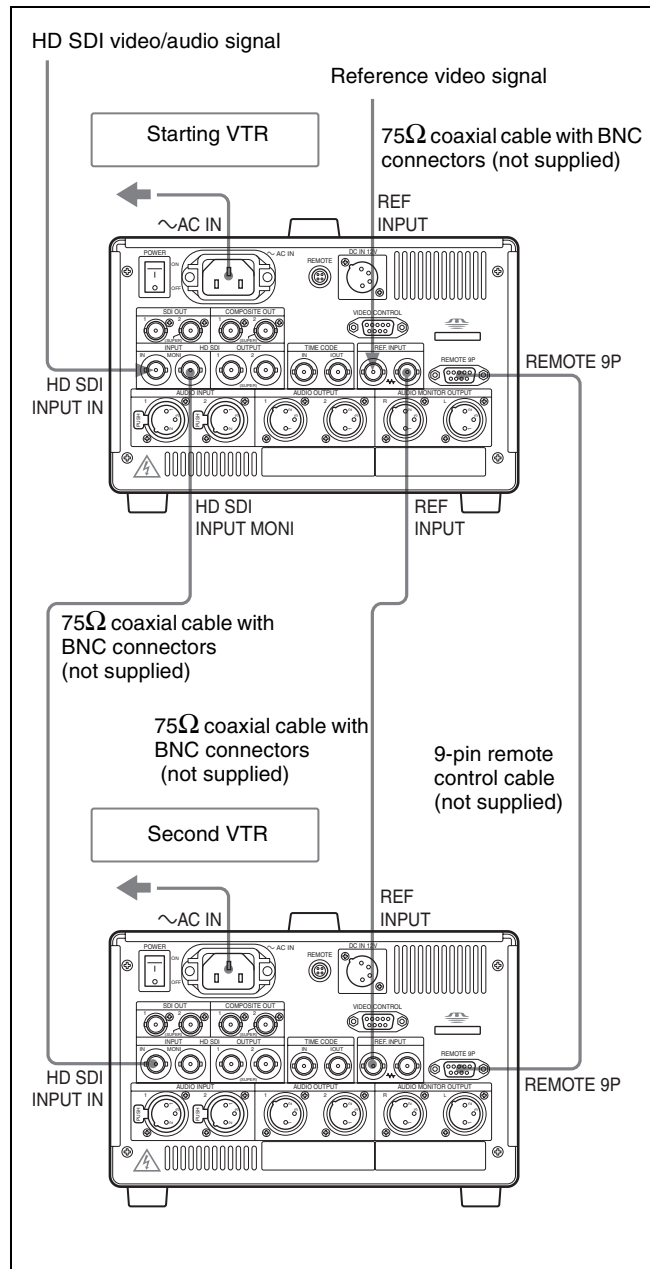

If you use only two cassettes, the last 78 minutes recorded can be obtained at any time.

If you change cassettes about every 38 minutes, endless recording is possible.

Follow the procedures below.

You can perform the front panel operations on the both units during sequential recording.

Note

Set the REMOTE button on the starting VTR not lit, and the REMOTE button on the other VTR lit beforehand. When the recording VTR is switched, recording is performed on the both VTRs for two minutes.

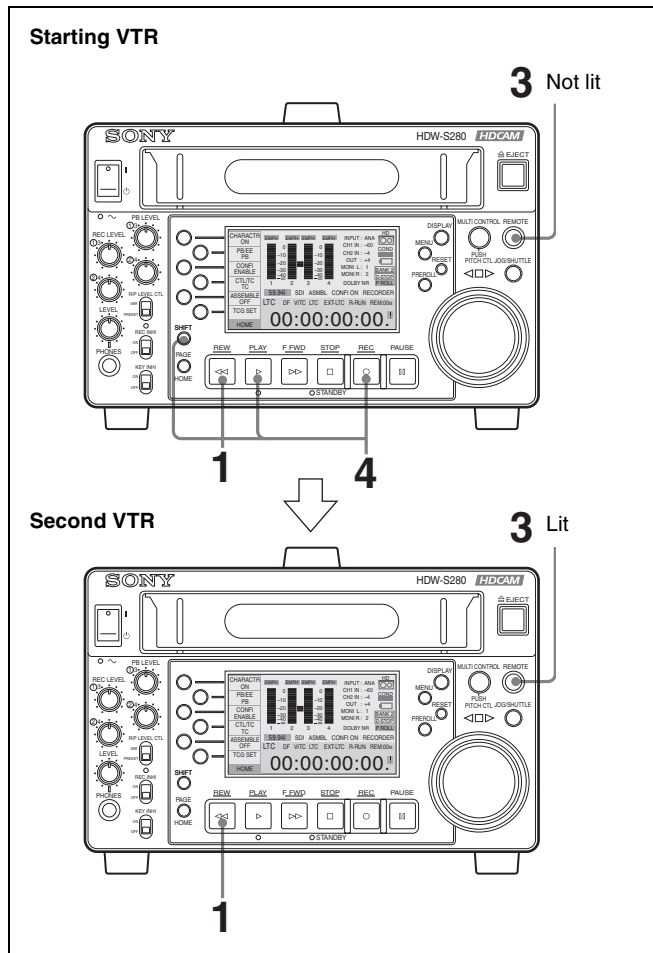

- 1 Insert the cassettes into the both VTRs and rewind the tapes all the way by pressing their REW buttons.
- 2 Set setup menu item 014 to a setting other than OFF.
- 3 Confirm that the REMOTE button on the starting VTR is not lit, and the REMOTE button on the other VTR is lit.
- 4 Press the second SHIFT button, REC button, and PLAY button on the starting VTR simultaneously.

Recording begins on the starting VTR, and the STANDBY indicator on the second VTR goes dark.

The second VTR starts recording automatically when the remaining time of the tape reaches 2 minutes on the currently-recording VTR.

The setting for setup menu item 014 affects what happens when recording ends.

When OVER (Automatic Overwrite) is selected

When recording ends, the tape is automatically rewound to the beginning, and recording continues, overwriting the previous contents repeatedly.

When REPL (Manual Cassette Replace) is selected

When recording ends, the tape stops at the end or is rewound to the beginning and stops according to the setting of setup menu item 125 "AUTO REWIND." When the tape stops, the cassette mark in the display window begins flashing. To continue recording, insert a new cassette into the VTR.

If you change a cassette during AUTO REW of the sequential recording, the VTR continues the sequential recording.

For details on setup menu item 125, see page 65.

To stop sequential recording

Sequential recording stops in the following cases:

- When a tape transport button (PLAY, STOP, F FWD, REW, EJECT) is pressed during recording
- If the cassette is not exchanged when the cassette mark flashes, even though setup menu item 014 is set to REPL (Manual Cassette Replace).

4-4 Playback

This section describes playback of tapes.

Note

When two HDW-S280 units are connected, press the REMOTE buttons on both VTRs so that they are not lit.

4-4-1 Preparations for Playback

Perform the following procedure.

- 1 Connect a cable to the video/audio signal input connectors of external equipment as necessary.
- 2 Select the audio output signals with MONITR L and MONITR R on the P3 AUDIO page of the function menu.
- 3 Select the time data with CTL/TC on the HOME page of the function menu.

For details on the function menu, see “3-7 Basic Operations of the Function Menu” on page 29.

If CTL is selected

You can reset the CTL to 0:00:00:00 by pressing the RESET button.

If TC/U-BIT is selected

You can select type of timecode (VITC/LTC/AUTO) with TCR on the P4 TC page of the function menu.

- 4 Select the convert mode on the setup menu depending on the format of the cassette to be played.

To play an HDCAM cassette

Select the down-convert mode with setup menu item 930.

For details on setup menu item 930, see page 75.

To play a Betacam SX or analog Betacam cassette

Select the up-convert mode with setup menu item 950.

For details on setup menu item 950, see page 76.

To output timecodes synchronized with the output video signal

The playback timecode or the timecode read by the timecode reader can be output via the TIME CODE OUT connector. To synchronize the timecode with the output video signal, follow the procedures below.

- 1 Set setup menu item 606 to REGEN.
For details on setup menu item 606, see page 68.
- 2 Set TCG on the P4 TC page of the function menu to INT.
- 3 Set PRST/RGN on the P4 TC page of the function menu to LTC or VITC.

For details on the function menu, see “3-7 Basic Operations of the Function Menu” on page 29.

4-4-2 Playback Operation

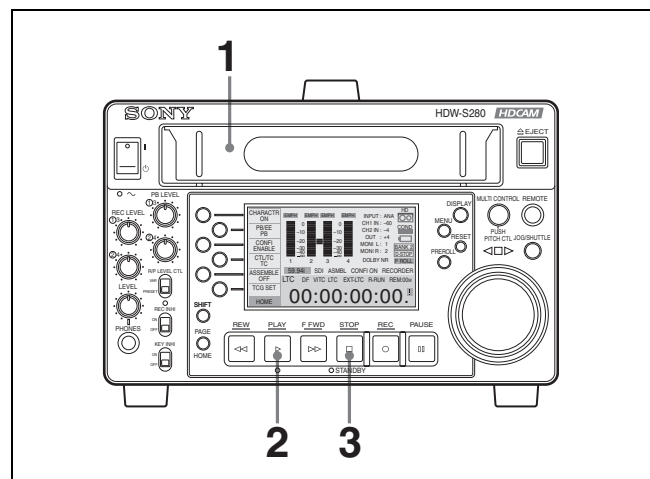

- 1 Insert a cassette to be played.
- 2 Press the PLAY button.
Playback begins.
- 3 Press the STOP button to stop playback.

To adjust the headphone audio level

Rotate the LEVEL adjustment knob.

To adjust the audio playback level

Set the R/P LEVEL CTL switch to VAR and rotate the PB LEVEL adjustment knobs. You can select the channels to be adjusted with setup menu item 826.

For details on setup menu item 826, see page 74.

If playback continues to the end of the tape

The tape automatically rewinds to the beginning and stops. You can set the unit to not rewind the tape automatically with setup menu item 125.

For details on setup menu item 125, see page 65.

4-4-3 Jog/Shuttle Mode playback**Playback in jog mode**

In jog mode, the playback speed depends on the rotation speed of the search dial. The adjustable range is ± 1 normal playback speed.

Proceed as follows for jog-mode playback:

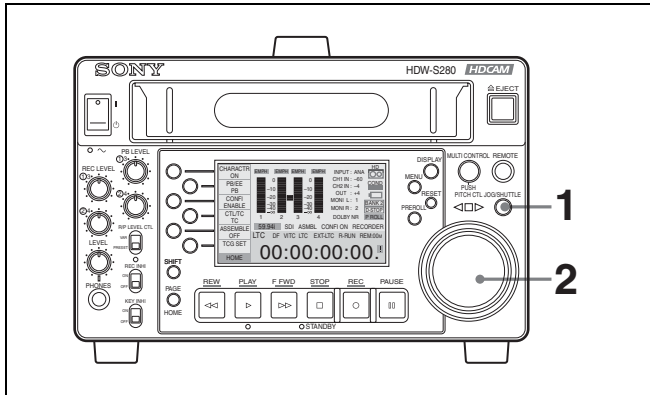

- 1** Press the JOG/SHUTTLE button.
- 2** Turn the jog dial in the direction indicated for the desired speed.

Jog-mode playback begins.

To stop jog-mode playback

Stop rotating the jog dial.

Playback in shuttle mode

In shuttle mode, playback speed depends on the angle of the search dial. The adjustable range is ± 10 normal playback speed.

Proceed as follows for shuttle-mode playback:

- 1** Press the JOG/SHUTTLE button.
- 2** Turn the shuttle ring toward the angle indicated for the desired speed.

Shuttle-mode playback begins.

To stop shuttle-mode playback

Return the shuttle ring to the center position or press the STOP button.

To play at normal speed

Press the PLAY button.

Direct jog/shuttle mode

If setup menu item 101 is set to DIAL, jog or shuttle playback is available without pressing the JOG/SHUTTLE button. Turning the shuttle ring (outer search dial) plays a tape in shuttle mode, and turning the jog dial (inner search dial) plays a tape in jog mode.

For details on setup menu item 101, see page 64.

5-1 Overview

When an HDW-S280 and editor or two HDW-S280 units and an editor are used in combination, you can perform assemble editing.

Note

Press the REMOTE button on the recorder VTR so that it is not lit and the REMOTE button on the player VTR so that it is lit beforehand.

5-1-1 Assemble Editing

In assemble editing, you record video and audio materials in order from the start of the tape. In addition to video, audio, CTL and timecodes are recorded. If a timecode is already recorded on the tape, the new timecode is recorded so as to form a continuous sequence with the existing timecode. Assemble editing is convenient when you are recording on a new tape.

Note

Before you begin assemble editing for the first time with a new tape, a video signal such as black signal, CTL, and a timecode must be recorded on the tape in advance of the recorder IN point for a length equal to or greater than the preroll time.

Selecting assemble mode

Set ASSEMBLE on the HOME page of the function menu to ON.

Note

For assemble editing, set TCR on the P4 TC page of the function menu to LTC or AUTO.

For details on the function menu, see “3-7 Basic Operations of the Function Menu” on page 29.

5-2 Automatic Editing

This section describes how to perform automatic editing with this unit and another VTR connected via the REMOTE 9P connector.

Sequence of editing operations

The sequence of editing operations using two HDW-S280 when units is as shown below.

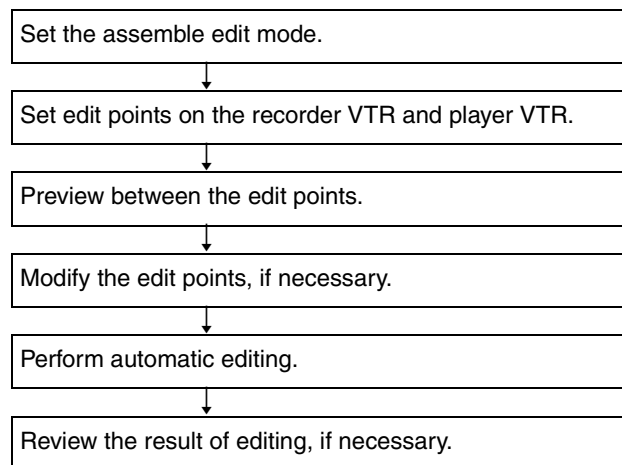

5-2-1 Setting the Edit Points

You can set the edit points on the recorder VTR and player VTR on the P5 EDIT page of the function menu.

Modifying an edit point

To modify an edit point, use the following procedure:

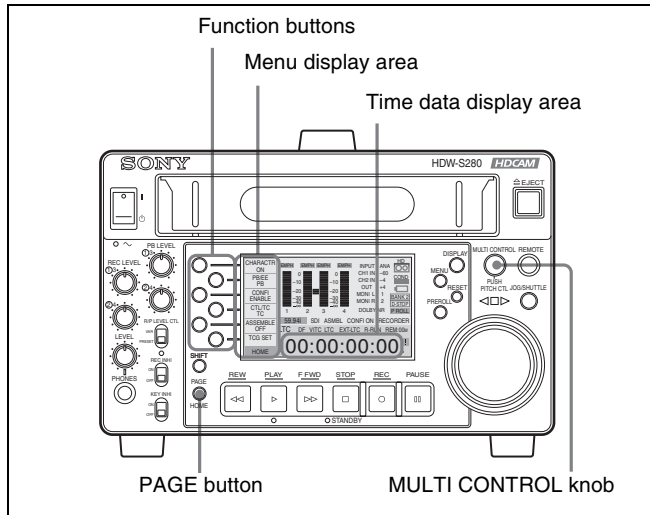

- 1 Press the PAGE button to display the P5 EDIT page in the menu display area.
- 2 Press the R/P function button to set a VTR (PLAYER or RECORDER) for modifying the edit points.
- 3 To modify the IN point, turn the MULTI CONTROL knob while holding the IN function button pressed.

To modify the OUT point, turn the MULTI CONTROL knob while holding the OUT function button pressed.

The time data displayed in the time data display area change. When the IN or OUT function button is released, the point at that moment is set as the IN or OUT point.

Deleting an edit point

To delete an edit point, use the following procedure (you can use the same procedure whether or not the DELETE indicator is flashing);

- 1 Press the R/P function button on the P5 EDIT page of the function menu to set a VTR (PLAYER or RECORDER) for deleting the edit points.
- 2 To delete the IN point, press the DELETE and IN function buttons simultaneously.

To delete the OUT point, press the DELETE and OUT function buttons simultaneously.

The IN or OUT point is deleted.

5-2-3 Cueing up to Edit Points and Prerolling

To preroll for the IN point or to cue up to any edit point, use the following procedure.

Cueing-up to edit points

Follow the procedure below.

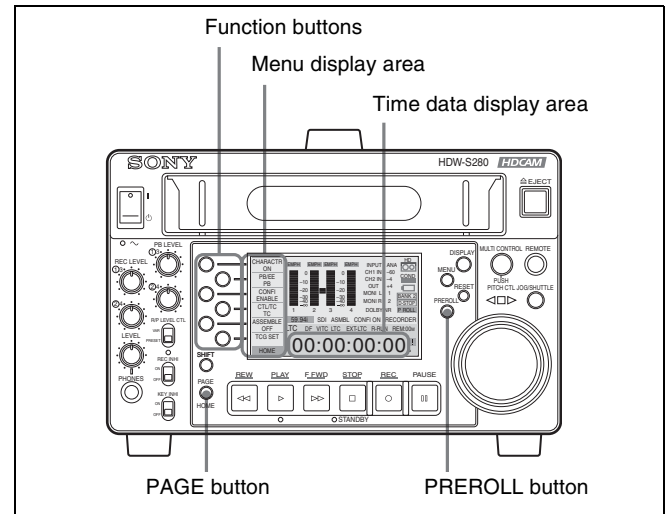

- 1 Press the PAGE button to display the P5 EDIT page in the menu display area.
- 2 Press the R/P function button to set a VTR (PLAYER or RECORDER) for cueing-up.
- 3 To cue up to the IN point, press the PREROLL button while holding down the IN function button.

To cue up to the OUT point, press the PREROLL button while holding down the OUT function button.

Cueing up to the IN or OUT point is finished, and PROLL appears at the Jog/Shuttle display position in the condition area of the display window.

Preroll

Press the PREROLL button. The tape is wound back to a position five seconds before the IN point and stops.

Changing the preroll time

The factory default setting for the preroll time is five seconds, but you can use setup menu item 001 to change this to any value from 0 to 30 seconds. If you change the preroll time, make sure that the setting is not longer than the recording length before the edit IN point. Note that for automatic editing, the preroll time setting on the recorder VTR takes precedence.

For details on setup menu item 001, see page 61.

5-2-4 Preview

When you have set the edit points, the PREVIEW indicator flashes in the menu display area. While the indicator is flashing, press the PREVIEW function button together with the SHIFT button. The PREVIEW indicator stays lit, and preview is performed.

Modify the edit points, if necessary, and perform preview again.

For details of modifying edit points, see “5-2-2 Modifying and Deleting Edit Points” on page 44.

To stop the preview

Press the STOP button. The tape stops where it was when you pressed the button.

To return the tape to the preroll point

Press the PREROLL button.

To return the tape to the IN point or OUT point

Press the PREROLL button together with the IN or OUT function button on the P5 EDIT page of the function menu.

Monitor output

During a preview, on a monitor connected to the recorder you can monitor the following video and audio:

- From the preroll point to the IN point, you can monitor the playback from the recorder VTR.
- From the IN point to the OUT point, you can monitor the playback from the player VTR through the recorder VTR in E-E mode.
- From the OUT point to the postroll point, you can monitor the playback from the recorder VTR.

The figure below illustrates this.

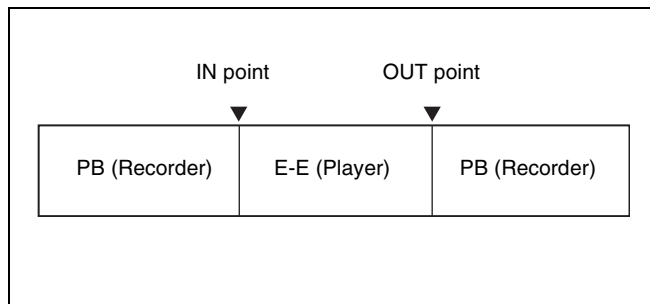

5-2-5 Performing Automatic Editing

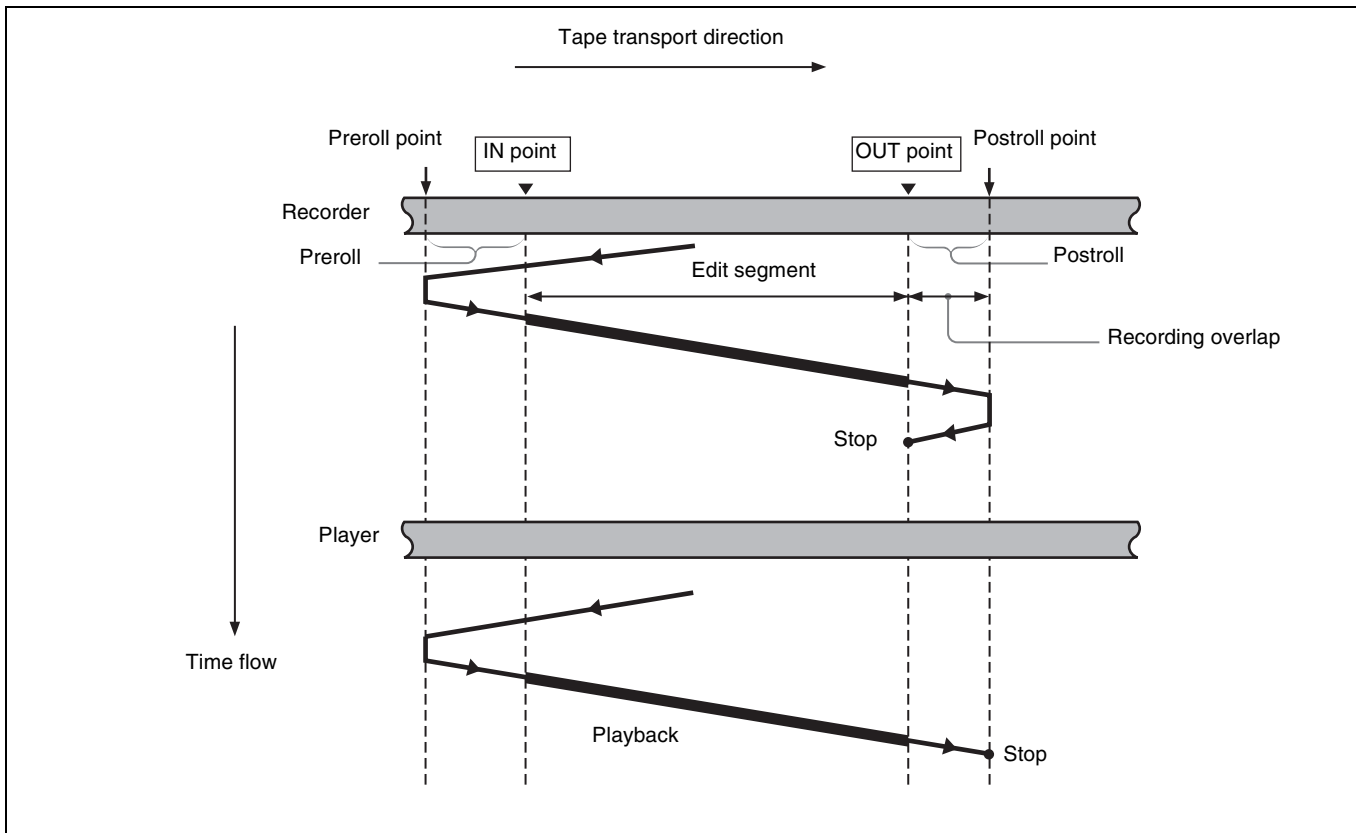

Overview

When you perform automatic editing, the recorder and player VTRs operate as shown in the figure above, to copy the video and audio signals between the IN and OUT points on the player VTR from the IN point on the recorder VTR.

Monitor output

During execution of an automatic edit, as during a preview, on a monitor connected to the recorder VTR you can monitor the following video and audio:

- From the preroll point to the IN point, you can monitor the playback from the recorder VTR.
- From the IN point to the OUT point, you can monitor the playback from the player VTR through the recorder in E-E mode.
- From the OUT point to the postroll point, you can monitor the playback from the recorder VTR.

The figure illustrates this.

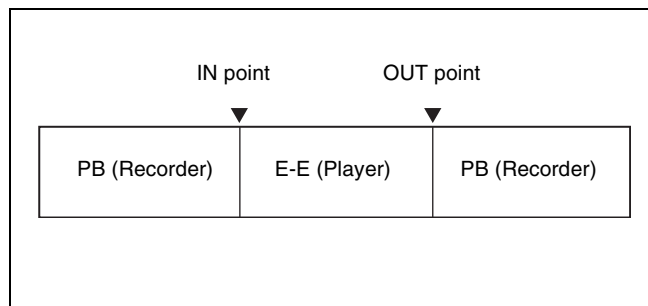

Using a single monitor for video and audio on both the player and recorder VTRs

For efficient editing if only one monitor is available, use the following method:

- 1 Connect the monitor to the recorder VTR.
- 2 Set setup menu item 008 to AUTO.

For details on setup menu item 008, see page 61.

- 3 Press the R/P function button on the P5 EDIT page of the function menu to select PLAYER.

This forces the recorder VTR to E-E mode, in which the player video and audio signals are output to the monitor.

Starting automatic editing

When you have set the edit points, the AUTOEDIT indicator in the menu display area starts flashing. Press the AUTOEDIT function button together with the SHIFT button.

The AUTOEDIT indicator changes from flashing to continuously lit, and the automatic editing operation begins.

At the end of the editing operation, the AUTOEDIT indicator goes dark.

To change the OUT point after starting an automatic editing operation

After starting the automatic editing operation, to end the operation before the preset OUT point, press the OUT function button together with the SHIFT button.

The position where you pressed the buttons becomes the OUT point, and editing ends.

To abandon automatic editing

Press the STOP button. The automatic editing operation is abandoned. The PREVIEW and AUTOEDIT indicators start flashing, and the state before the editing was started is restored.

In this case, the IN and OUT points already set are preserved so that you can perform a preview or automatic editing operation.

To reviewing the editing results

After an editing operation, you can review the editing results on the monitor.

To review, after performing the automatic editing, and before you set any new edit points or make other settings, press the REVIEW function button.

The REVIEW indicator lights, and the editing results are reviewed.

At the end of the review, the REVIEW indicator starts flashing again, and the tape returns to the OUT point.

To modify the edit points and reexecute the edit after automatic editing

Press the DELETE function button together with the SHIFT button to retrieve the edit points. After modifying the edit points, perform automatic editing again.

For details of modifying edit points, see “5-2-2 Modifying and Deleting Edit Points” on page 44.

5-2-6 First Edit Function

The first edit function automatically creates a base tape. Set the timecode value for the start of recording in setup menu item 614.

You can also specify the number of seconds before this timecode value at which the recording starts, using setup menu item 615. Select the video signal to be recorded on the tape with setup menu items 710 and 808. If setup menu items are set to OFF, CB75 and SILNC are selected. Use the following procedure to create a base tape.

1 Set setup menu item 614 to ON.

For details on setup menu item 614, see page 69.

2 Set the starting timecode value.

For details of the setting procedure, see “3-6 Setting Timecode” on page 26.

3 With setup menu item 615, set the number of seconds before the timecode value set in step **2** from which you want recording to start (10 to 30 seconds).

For details on setup menu item 615, see page 69.

4 Hold down the REC button and press the AUTO EDIT button on P5 EDIT page of the function menu.

This switches the unit to First Edit mode.

6-1 Overview

This unit can record shot marks or use shot marks recorded with HDCAM comcorders or Betacam SX camcorders (shot mark function). The shot mark function enables quick access to the marked points, for efficient editing. When shot data are recorded on the tape, you can display the data and make use of them for sorting shot marks.

6-1-1 Shot Mark/Shot Data Function Features

The shot mark function has the following features:

Recording shot marks

You can record shot marks at any position on a tape by setting it with setup menu item 631.

For details on setup menu item 631, see page 70.

Cueing up shot marks

You can cue up the previous or next shot mark by pressing the REW or F FWD button together with the SHIFT button. The type of the cued-up shot mark is indicated in the condition area. You can select the type of shot mark to be cued up with setup menu item 630.

For details on setup menu item 630, see page 70.

Displaying shot data

Shot data are the data on recording at each recording. Press the PLAY button together with the SHIFT button to display the shot data. The tape is played, and the data shown below are displayed.

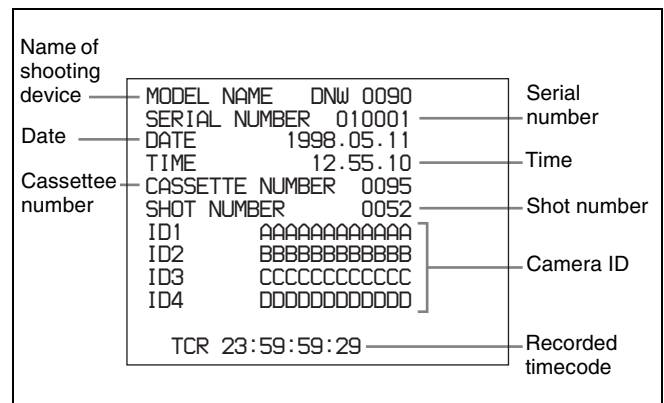

The content of the display changes as the shooting conditions change (for example, the date and time or shooting device change). Sections where no data are recorded because you changed the shooting device are blank.

To go out the display

Press the PLAY button together with the SHIFT button.

7-1 Stop Code

You can record, detect, and erase stop codes conforming to the NAB-T007-1990 standards.

The stop code is recorded for 20 frames at a point four seconds before the SOM (start of program). When this code is detected during playback, the tape stops at the designated point.

The point to stop the tape can be adjusted by modifying the following two settings:

- Point to stop the tape after detecting the stop code: 0 to 30 frames in units of frames
- Point to start recording the stop code: 1 to 5 seconds in units of seconds (to SOM)

The recording format of the stop code is as shown below.

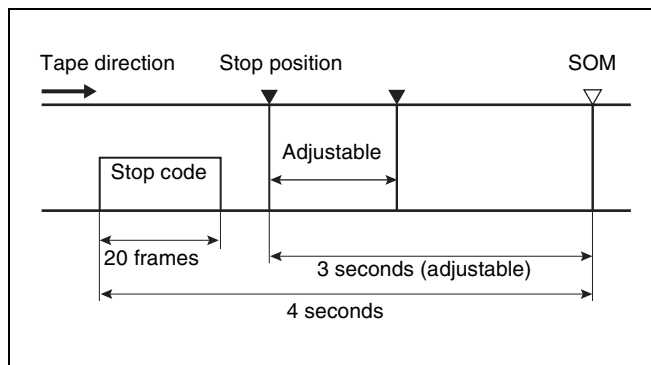

7-2 Stop Code Operation

This section describes the operations for detecting or recording stop codes.

7-2-1 Detecting the Stop Code

Detecting the stop code

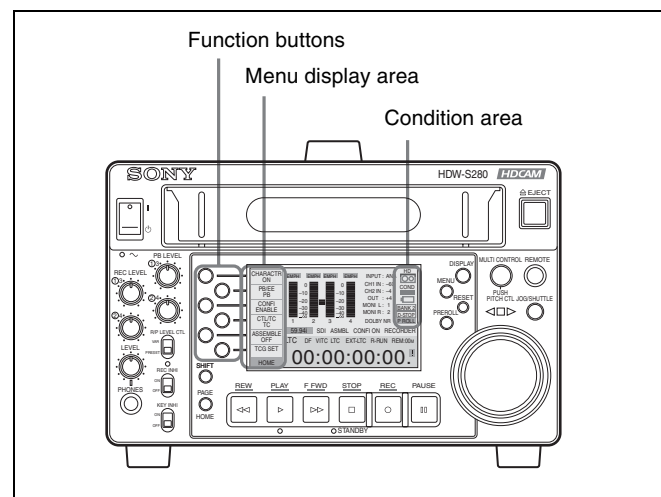

- 1 Select STOPCODE on the P6 OTHER page of the function menu.

The STOPCODE page appears.

DETECT OFF
REC/ERAS REC
REC
ERASE
CHECK
EXIT
STOPCODE

2 Press the DETECT function button to set it to ON.

D-STOP appears in the condition area of the display window, and you can detect the stop code.

If three or more stop codes are detected during playback, the tape stops, and D-STOP flashes.

Adjusting the stop position when detecting the stop code

You can modify the stop position by 0 to 30 frames to SOM from the normal position with STOP ADJUST, a submenu item of setup menu item 138.

For details on setup menu item 138, see page 65.

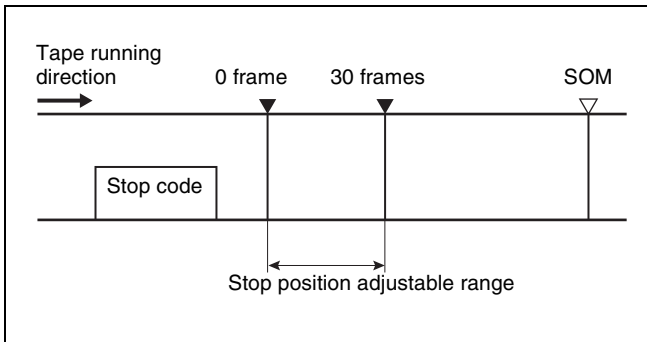

7-2-2 Recording the Stop Code

Recording the stop code

Proceed as follows.

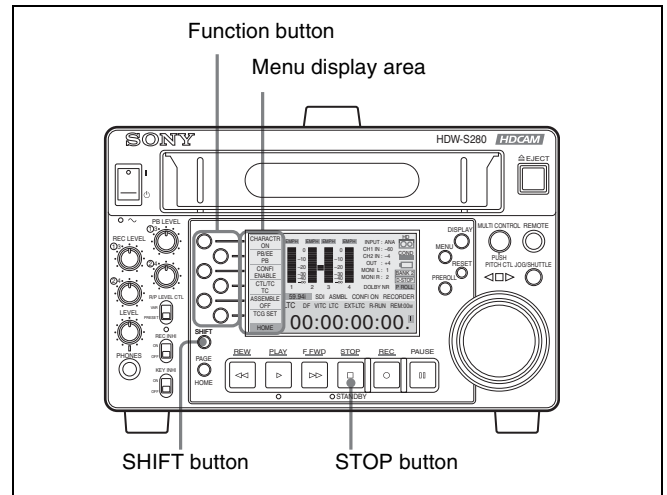

1 Select STOPCODE on the P6 OTHER page of the function menu.

The STOPCODE page appears.

2 Press the REC/ERAS function button to set REC.

3 Play the tape, and stop it at the position to record the stop code.

4 Press the REC function button on the STOPCODE page together with the SHIFT button.

The stop code is recorded.

When the stop code is recorded, the setting in step 2 is automatically set to OFF.

While recording a stop code, the menu for the timecode required for recording the stop code is selected independently of the settings for TCG and PRST/RGN on the P4 TC page of the function menu.

To interrupt the operation

Press the STOP button.

Checking the Recorded Stop Code

Press the CHECK function button on the STOPCODE page selected from the submenu of the P6 OTHER page of the function menu together with the SHIFT button. The tape is prerolled to nine seconds before SOM and is played. If the stop code is recorded correctly, the tape stops depending on the setting for STOP ADJUST, the sub item of setup menu item 138, independently of the setting for DETECT on the STOPCODE page.

For details on setup menu item 138, see page 65.

Adjusting the stop position by modifying the starting point for recording a stop code

You can modify the position at which to start recording the stop code by 1 to 5 seconds in units of seconds with REC ADJUST, a submenu of setup menu item 138.

For details on setup menu item 138, see page 65.

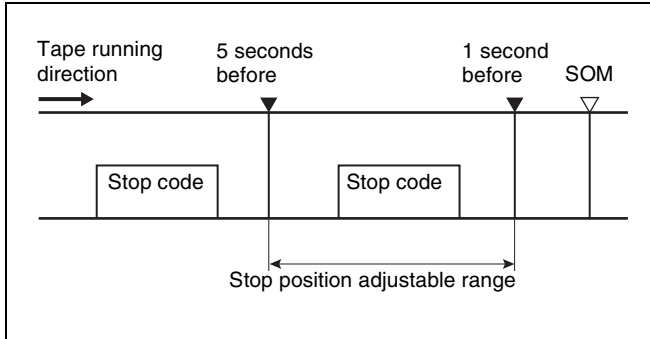

7-2-3 Erasing the Stop Code

Erasing the stop code

Proceed as follows.

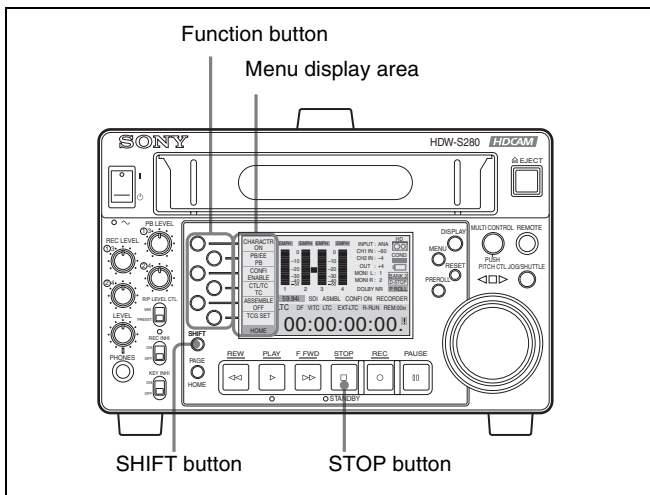

- 1 Select STOPCODE on the P6 OTHER page of the function menu.

The STOPCODE page appears.

- 2 Press the REC/ERAS function button to set ERASE.
- 3 Play the range including the stop code to be erased from the tape.

The tape stops when the stop code is detected.

- 4 Press the ERASE function button on the STOPCODE page together with the SHIFT button.

The tape is prerolled to five seconds before the point where the stop code is recorded, and erasing of the stop code begins.

When erasing the stop code is finished, the setting made in step 2 is automatically set to OFF.

When a stop code is being erased, the menu for the timecode required for recording the stop code is selected independently of the settings for TCG and PRST/RGN on the P4 TC page of the function menu.

To interrupt the operation

Press the STOP button.

Checking stop code erasure

Press the CHECK function button on the STOPCODE page together with the SHIFT button. The tape is prerolled to five seconds before the point where the stop code is record, and playback starts. If the tape stops at the position where the stop code was recorded, the erasure operation must be performed again.

8-1 Overview of UMID Functions

UMID (Unique Material Identifier) is a type of meta-data in video and audio materials. It has been internationally standardized in SMPTE Standard 330M. This unit supports recording and generation of UMIDs.

UMID is made up of a section called the Basic section and a section called the Source Pack section. The Basic section contains information such as the device that recorded the material and whether the material is the original or a copy. The Source Pack section contains information about when/where/who recorded the material.

UMID with a Basic section only is called a Basic UMID. UMID with both Basic and Source Pack sections is called Extended UMID. The figure below gives a general overview of the information contained in a UMID.

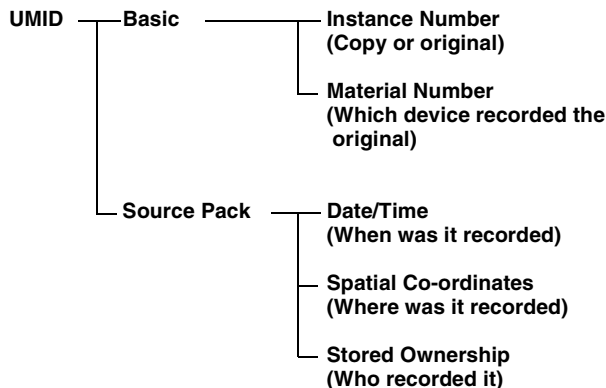

8-2 Recording UMIDs

UMIDs can be recorded when recording video signals with this unit. You can select whether to inherit (copy) the UMID contained in input signals automatically or forcibly generate a new UMID.

Selecting the type of UMID to record

Select whether to record Basic UMID or Extended UMID, using setup menu item 655.

For details on setup menu item 655, see page 71

Selecting whether to inherit or generate UMID

When recording UMID, you can select whether to inherit (copy) UMID contained in input signals, or generate new UMID. Make this selection by using setup menu item 656.

For details on setup menu item 656, see page 71

Selecting the Instance Number generation method when inheriting UMID

If you choose to inherit UMID contained in input signals, almost all of the information in the UMID is copied without change, but the Instance Number changes to a value that indicates that “this UMID is a copy.” The new value can be generated from a 16-bit pseudo-random number with the addition of the number of copies (1 byte), or it can be generated from a 24-bit pseudorandom number. Select the method used to generate the Instance Number by using setup menu item 654.

For details on setup menu item 654, see page 70.

Selecting the SDI VANC line to insert UMID

You can select the VANC (Vertical ancillary) line into which the generated UMID should be inserted. Make this selection by using setup menu item 653.

For details on setup menu item 653, see page 70.

Setting Stored Ownership

If you wish to set Stored Ownership (data in the Source Pack which indicates “who”) when generating a UMID, call up item 029 of the setup menu and proceed as follows.

For details on setup menu item 029, see page 62.

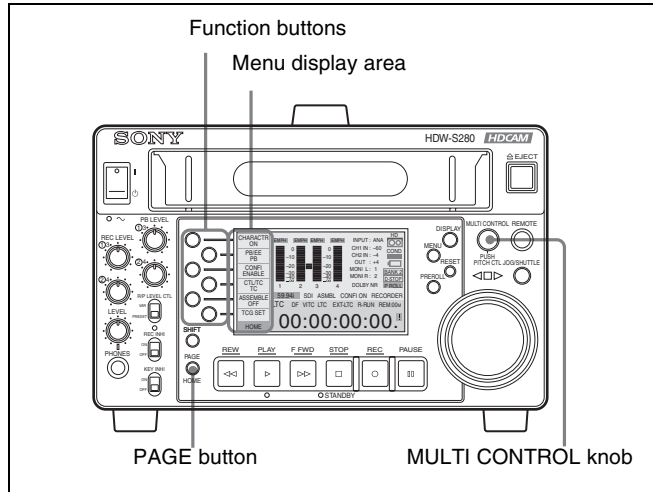

- 1 Display setup menu item 029.

For details on making settings on the setup menu, see “9-2 Setup Menu Operations” on page 58.

- 2 Turn the MULTI CONTROL knob to display PUSH SET.
- 3 Press the SET function button.

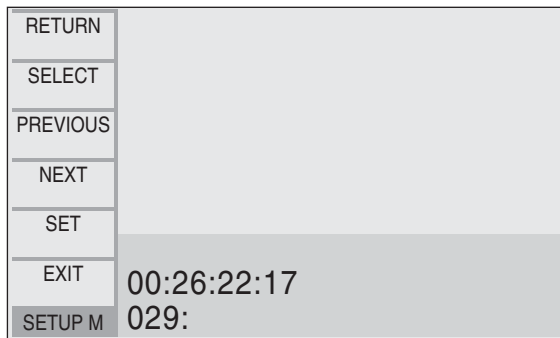

The STORED OWNERSHIP display appears on the monitor screen.

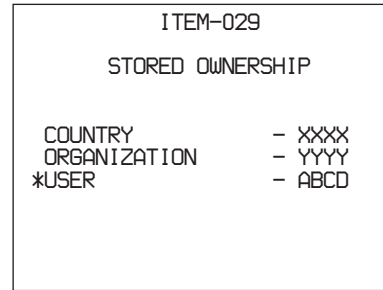

- 4 Press the PREVIOUS or NEXT function button to select an item to be set (COUNTRY, ORGANIZATION, USER).

- 5 Press the SELECT function buttons.

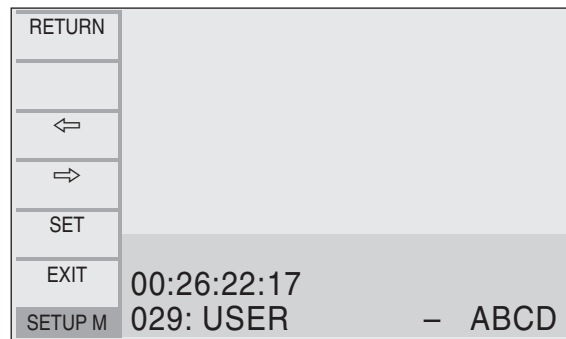

- 6 Press the ← or → function button to select a character to be changed from the set character string, ABCD in this example.

The selected character flashes.

- 7 Turn the MULTI CONTROL knob to display the desired character in place of the flashing one.

Repeat steps 6 and 7 for all characters to be changed.

- 8 To set another item (COUNTRY or ORGANIZATION), press the RETURN function button and repeat steps 4 through 7.

To not set another item, proceed to step 9.

- 9 Press the SET function button.

The changed settings are registered.

To cancel the settings

Press the EXIT function button. The unregistered settings are abandoned.

Time zone settings

UMID uses the UTC (Coordinated Universal Time) time standard. Setting the built-in calendar clock to the local time and then setting a time zone to indicate the difference

from global UTC standard time allows correct UMIDs to be generated.

To set the time zone, display the HOME page of the function menu and proceed as follows:

- 1 Press the MENU button together with the SHIFT button.

The error logger display appears.

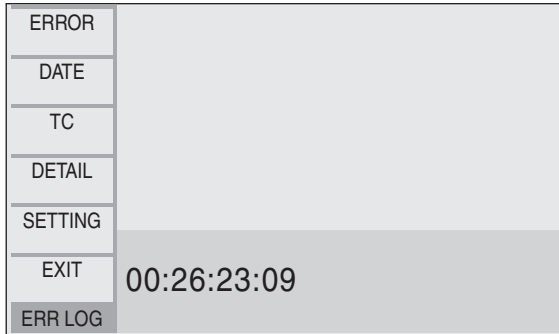

For details on the error logger, refer to the Maintenance Manual Volume 1.

- 2 Press the SETTING function button

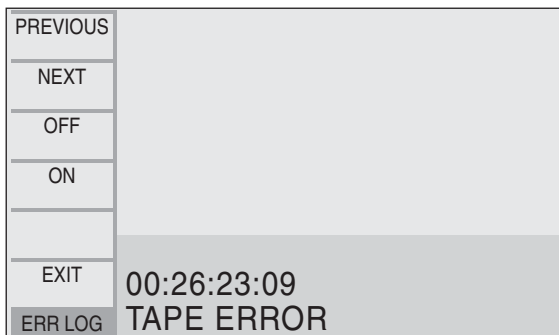

- 3 Press the PREVIOUS or NEXT function button to display OFFSET TO UTC in the time data display area.

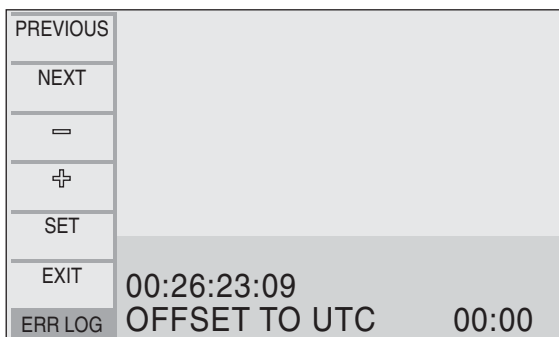

On the monitor screen, the ERROR LOGGER display appears, and * mark appears before OFFSET TO UTC.

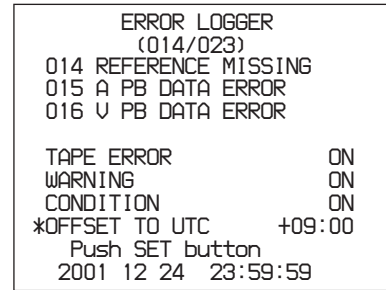

- 4 Turn the MULTI CONTROL knob or press the – or + function button to set the offset from UTC time.

For example, if the local time is 9 hours in advance of UTC, set +09:00.

- 5 Press the SET function button.

The setting is registered.

8-3 UMID Output and Display

This section explains how to output and display UMIDs.

8-3-1 UMID Output Settings

You can choose to output UMIDs or not and select either Basic UMID or Extended UMID when you choose to output UMIDs. Make these settings using setup menu item 651.

For details on setup menu item 651, see page 70.

8-3-2 UMID Display

During recording and playback, UMID data appear in the time data display area of the display window and on the video monitor screen.

Displaying the UMID

Press the UMID function button on the P6 OTHER page of the function menu.

For details on function menu operation, see “3-7 Basic Operations of the Function Menu” on page 29.

The UMID appears in the time data display area of the display window and on the video monitor screen.

For UMID display on the video monitor screen, see “UMID display on the video monitor” on page 56.

To switch the displayed UMID item in the time data display area

Turn the MULTI CONTROL knob.

To exit from UMID display

Press the EXIT function button.

UMID display on the video monitor

The video monitor connected via the COMPOSITE OUT 2 (SUPER) connector, the SDI OUT 2 (SUPER) connector, or the HD SDI OUTPUT (SUPER) connectors on the rear panel displays all UMID items at once. The display of each line is explained below.

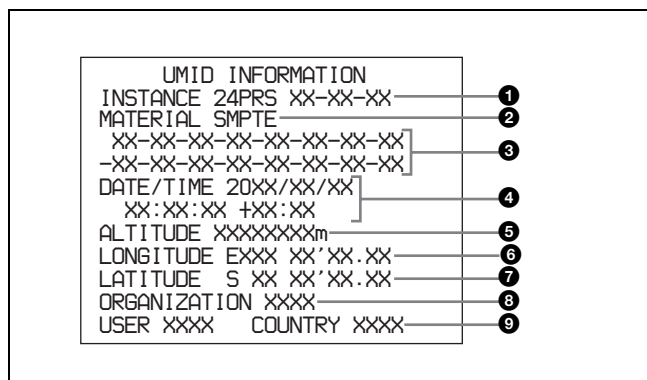

① INSTANCE (Instance Number generation method and Instance Number)

The generation method is displayed as follows.

CP+16: 16-bit PRS (pseudorandom sequence) +Copy No. method

24PRS: 24-bit PRS method

others: Other than the above

When menu item 656 is set to NEW, the number is generated in the SMPTE format.

For details on setup menu item 656, see page 71.

② MATERIAL (Material Number generation method)

SMPTE: SMPTE format

IEEE 1394 ZONE: IEEE 1394 ZONE format

IEEE 1394 RND: IEEE 1394 RND format

others: Other than the above

③ Material Number

The material number is displayed in hexadecimal across two lines.

The items ④ through ⑨ below are contained in the Source Pack.

④ DATE/TIME

Date/Time data are displayed across two lines.

The upper line shows the MJD (Modified Julian Date) contained in the Source Pack, converted to UTC.

The lower line shows the data in unit count format (hours:minutes:seconds) converted to UTC.

Note

The function for converting unit count to UTC works only when the unit rate is 2 (24 frames), 3 (24/1.001 frames), 4 (25 frames), 6 (30 frames), or 7 (30/1.001 frames). For other unit rates, the unit rate number and unit rate are displayed in hexadecimal.

⑤ ALTITUDE

XXXXXXXXm: Altitude data indicating the distance from the center of the earth is displayed in this format.

S+XXXXXXXXm Y+D: Altitude data indicating the distance from sea level is displayed in this format. The meaning of the characters and strings shown is as follows.

S (1st character): Indicates data from a Sensor. R is shown for position data from the recording device (Recorder), and T is shown for Target position data.

+ (2nd character): Indicates higher than sea level. – indicates lower than sea level.

XXXXXXXXm: Altitude data (in unit of meters).

Y: The number of satellites used to calculate position data (hexadecimal)

D: DOP (Dilution of Precision) value

+ (between Y and D): Displayed when a support apparatus was used. A space (blank) is displayed when no support apparatus was used.

⑥ LONGITUDE

Following W to indicate west longitude or E to indicate east longitude, the longitude is displayed in degrees, minutes, and seconds (seconds are shown in up to 2 decimal places).

Example: E134 59'23"00 for East longitude 134 degrees 59 minutes 23 seconds 00

⑦ LATITUDE

Following N to indicate north latitude or S to indicate south latitude, the latitude is displayed in degrees, minutes, and seconds (seconds are shown in up to 2 decimal places).

Example: N34 59'23"32 for North latitude of 34 degrees 59 minutes 23 seconds 32

⑧ ORGANIZATION

Organization code

⑨ USER/COUNTRY

User code and country code

9-1 Setup Menu Configuration

This unit has the following setup menus.

- Basic setup menu
- Extended setup menu

For details, refer to the maintenance manual

In this manual, both the basic setup menu items and extended setup menu items are also referred to simply as setup menu items or menu items.

9-2 Setup Menu Operations

9-2-1 Displaying Setup Menus

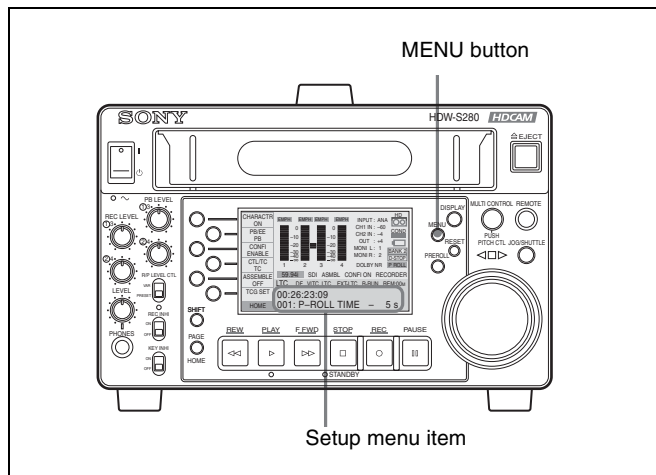

Press the MENU button, and the currently selected setup menu item appears in time data display area.

To display menus on the monitor

Setting CHARACTER on the HOME page of the function menu to ON allows you to display setup menus on the monitor connected to the COMPOSITE OUT 2 (SUPER) connector, HD SDI OUTPUT (SUPER) connectors or SDI OUT 2 (SUPER) connector of this unit. When a setup menu appears on the monitor, a cursor indicates the currently selected menu item.

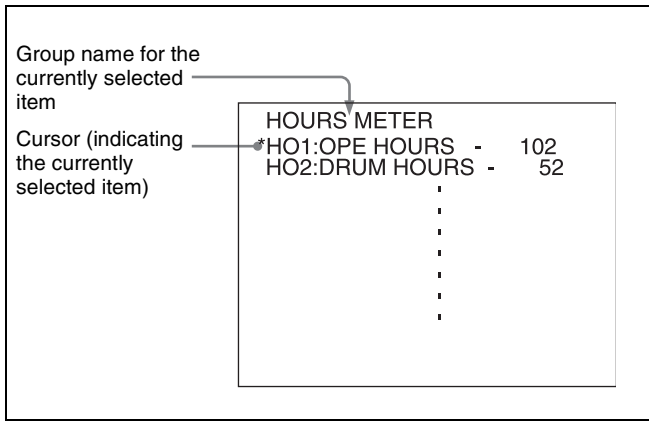

9-2-2 Setting Setup Menu

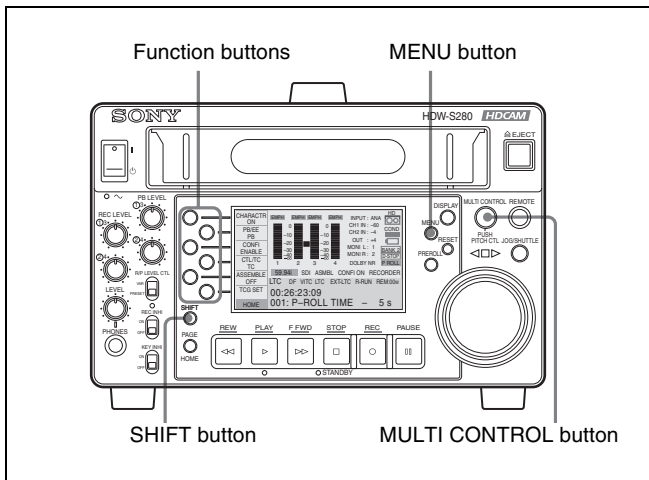

1 Press the MENU button.

The currently selected setup menu item appears in the time data display area.

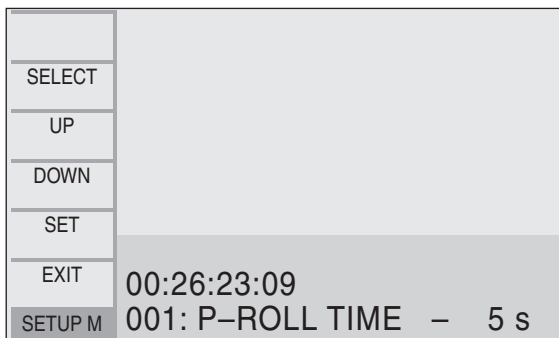

2 Turn the MULTI CONTROL knob to display a desired item.

Press the UP or DOWN function button changes the displayed item by 100 units.

3 Press the SELECT function button to select the displayed item.

If a submenu exists, turn the MULTI CONTROL knob to select a submenu, and press the SELECT function menu.

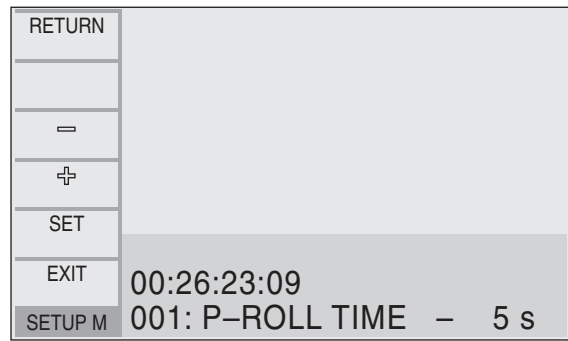

4 Turn the MULTI CONTROL knob to change the setting.

Turning the MULTI CONTROL knob after pressing it changes the value rapidly. Pressing the button again retrieves the original speed.

Pressing the – or + function button also changes the setting.

5 Press the SET function button to define the changed setting.

To change the other items, repeat steps **1** through **5**.

To interrupt setting

Press the EXIT function button before pressing the SET function button in step **5**.

To return to the previous step

Press the RETURN function button.

Resetting the menu settings to their factory default values (menu item B20)

To reset the current active menu settings to their factory default values, proceed as follows.

1 Press the MENU button.

2 Turn the MULTI CONTROL knob to display setup menu item B20.

3 Press the SELECT function button to select the displayed setup menu item B20.

4 Turn the MULTI CONTROL knob to set B20 to ON, and press the SET function button.

The current active menu settings are reset to their factory default settings.

5 Press the SET function button.

This saves the menu settings.

Switching the system frequency (menu item 013)

To switch the system frequency, proceed as follows.

Note

- Before carrying out this operation, consult the person responsible for system installation.
- When the unit is used in 50i mode, only an analog tape can be played back in the simple playback mode.

- 1 Press the MENU button.
- 2 Turn the MULTI CONTROL knob to display setup menu item 013.
- 3 Press the SELECT function button to select the displayed setup menu item 013.
- 4 Turn the MULTI CONTROL knob or press the – or + function button to display PUSH SET.
- 5 Press the SET function button.
- 6 Turn the MULTI CONTROL knob or press the – or + function button to select the system frequency.
- 7 Press the SET function button.
TURN OFF/ON POWER!! appears.
- 8 Turn the power OFF.
When the power is turned next, the unit operates in the selected mode.

BANK 1 or B02 RECALL SETUP BANK 2 to ON, then press the SET function button.

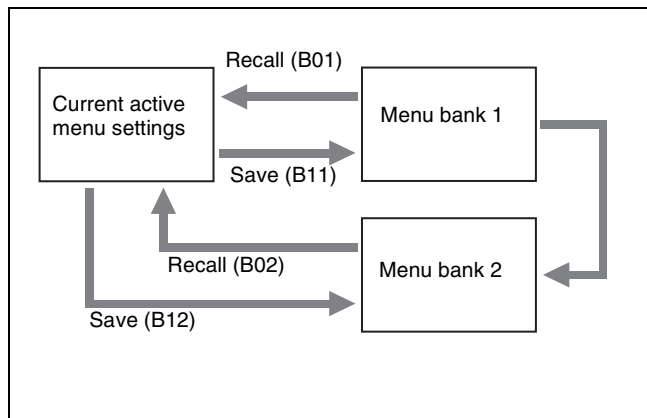

9-2-3 Menu Bank Operations (menu items B01 to B12)

This unit allows menu settings to be saved in menu banks. Saved sets of menu settings can be recalled for use as required. The current active setup menu settings as well as settings saved in menu banks are stored in separate storage areas for 50i and 59.94i modes.

Saving the current active menu settings

Set menu items B11 SAVE SETUP BANK 1 or B12 SAVE SETUP BANK 2 to ON, depending on which of the menu banks you wish to save in, then press the SET function button.

Recalling settings from a menu bank

When recalling the settings saved in menu banks 1 or 2, set the corresponding menu items B01 RECALL SETUP

9-3 Items in the Basic Setup Menu

The basic setup menu contains the following items.
In the Settings column of the table, the factory setting is indicated by enclosing parenthesis.

Item number	Item name	Settings
001	PREROLL TIME	0S~[5S]~30S : Set the preroll time to between 0 and 30 seconds. A preroll time of at least 5 seconds is recommended when using this unit for editing.
002 ^{a)}	CHARACTER H-POSITION	Adjust the horizontal screen position of the character information output from the COMPOSITE OUT 2 (SUPER) connector, HD SDI OUTPUT (SUPER) connectors, and SDI OUT 2 (SUPER) connector for superimposed display on the monitor. 00~[1E]~3C (59.94i, 29.97PsF mode)/00~[1B]~36 (50i, 25PsF, 24PsF, 23.98PsF mode) : The hexadecimal value 00 is for the far left of the screen and increasing the value moves the position of the characters to the right.
003 ^{a)}	CHARACTER V-POSITION	Adjust the vertical screen position of the first line of the character information output from the COMPOSITE OUT 2 (SUPER) connector, HD SDI OUTPUT (SUPER) connectors, and SDI OUT 2 (SUPER) connector for superimposed display on the monitor. 00~[59]~73 (59.94i, 29.97PsF mode)/00~[70]~8A (50i, 25PsF, 24PsF, 23.98PsF mode) : The hexadecimal value 00 is for the top of the screen and increasing the value lowers the position of the characters. Note When displaying timecode, there is a slight time delay. Therefore, when creating a tape for off-line editing, the information inserted in the upper half of the screen may be delayed by one frame.
004	SYNCHRONIZE	When editing using this unit as a controller and an external VTR connected to this unit via a 9-pin remote control cable, this item determines whether or not to operate the two units in phase synchronization. OFF : Do not operate in phase synchronization. [ON] : Operate in phase synchronization.
005	DISPLAY INFORMATION SELECT	Determines the kind of character information to be output from the COMPOSITE OUT 2 (SUPER) connector, HD SDI OUTPUT (SUPER) connectors, and SDI OUT 2 (SUPER) connector when CHARACTER on the HOME page of the function menu is set to ON. [T&STA] : Time data display information and the status of the unit T&UB : Time data display information and the user bit T&CTL : Time data display information and CTL T&T : Time data display information and timecode (LTC or VITC) TIME : Time data display information only If there is an overlap between the setting for this item and the setting for the front panel, it is automatically avoided. For example, if CTL is selected on the front panel and this menu item setting is T&CTL, then CTL and LTC are output.
006	LOCAL FUNCTION ENABLE	Determines which buttons on the front panel are enabled when this unit is controlled from external equipment. DIS : All buttons and switches other than DISPLAY and PAGE buttons are disabled. [S&E&F] : Only the STOP button, EJECT button, and function buttons are enabled. ENA : All buttons and switches are enabled.
007	TAPE TIMER DISPLAY	Determines whether to display the CTL count in 12-hour mode or 24-hour mode. [+-12H] : 12-hour mode 24H : 24-hour mode
008	MONITORING SELECTION FOR VTR-TO-VTR EDIT	For recorder-player editing with only one monitor connected to the recorder, determines whether the recorder is forced into E-E mode when R/P on the P5 EDIT page of the function menu is set to PLAYER to view the player's playback signals on the monitor. [MANU] : Do not force the recorder into E-E mode. AUTO : Force the recorder into E-E mode.

Item number	Item name	Settings
009 ^{a)}	CHARACTER TYPE	Determines the type of characters such as timecode output from the COMPOSITE OUT 2 (SUPER) connector, HD SDI OUTPUT (SUPER) connector, and SDI OUT 2 (SUPER) connector for superimposed display on the monitor. [WHITE]: White letters on a black background BLACK: Black letters on a white background W/OUT: White letters with black outline B/OUT: Black letters with white outline
011 ^{a)}	CHARACTER V-SIZE	Determines the vertical size of characters such as timecode output from COMPOSITE OUT 2 (SUPER) connector, HD SDI OUTPUT (SUPER) connectors, and SDI OUT 2 (SUPER) connector for superimposed display on the monitor. [×1]: Standard size ×2: 2 times standard size
012	CONDITION DISPLAY ON VIDEO MONITOR	Determines whether the channel condition is superimposed on the superimposed characters. [DIS]: Not displayed ENA: Displayed To display The channel condition is displayed below the timer or status display. Example) V-A- A character following V indicates the status of the video channel on the rotary head. A character following A indicates the status of the audio channel on the rotary head. Character pattern —: Good *: Not good ■: Bad
013	SYSTEM FREQUENCY SELECT	Specify whether to enable switching of the system frequency between 59.94i, 50i, 29.97PsF, 25PsF, 24PsF, and 23.98PsF. [OFF]: Disable switching. ON: Enable switching. When ON is selected, the menu display changes to allow switching of the setting between 59.94i, 50i, 29.97PsF, 25PsF, 24PsF, and 23.98PsF. For the procedure for switching the system frequency, see “Switching the system frequency (menu item 013)” on page 60. Notes <ul style="list-style-type: none"> For the basic and extended setup menus, separate settings are saved for 59.94i, 29.97PsF mode, 50i, 25PsF mode, and 24PsF, 23.98PsF mode. When you switch systems, all menu items change to the settings established in the new system. (The settings are different from those for the mode before switching.) When the unit is used in 50i, 29.97PsF mode, analog tape can only be played back in the simple playback mode.
014	SEQUENTIAL RECORD MODE	Selects the method for sequential recording using two HDW-S280 units. [OFF]: No sequential recording REPL: For one time sequential recording. Every time a sequential recording ends, replace a cassette. OVER: For repeated sequential recording by overwriting. (No cassette replacement)
028	HD CHARACTER	Sets whether character information is superimposed or not to the video signal output from the HD SDI OUTPUT (SUPER) connectors. [OFF]: Not superimposed F-KEY: Depending on the setting for the function menu.
029	STORED OWNERSHIP	Select whether or not to set the Stored Ownership UMID item. [OFF]: Do not set. ON: Set. <i>To set Stored Ownership, see “Setting Stored Ownership” on page 54.</i>
033	BATTERY END VOLTAGE	Sets the voltage to shut down the unit in the battery operation. The battery near end indicator flashes at +0.7 V of the set voltage. [10.5V]~13.5V: 10.5 V to 13.5 V in 0.5 V unit.
B01	RECALL SETUP BANK 1	Set to ON to recall menu settings from menu bank 1.
B02	RECALL SERTUP BANK 2	Set to ON to recall menu settings from menu bank 2.
B11	SAVE SETUP BANK 1	Set to ON to save current active menu settings to menu bank 1.

Item number	Item name	Settings
B12	SAVE SETUP BANK 2	Set to ON to save current active menu settings to menu bank 2.
B20	RESET CURRENT SETUP	Set to ON to reset current active menu settings to factory default values.

- a) To set items 002, 003, 009, and 011, watch the monitor and adjust to the desired status.

9-4 Items in the Extended Setup Menu

The expanded setup menu contains the following items. In the Settings column of the table, the factory setting is indicated by enclosing parenthesis.

Note

Items 900 to 999 are not applicable in 24PsF/23.98PsF mode.

Items 100 to 199: Settings for the front panel

Item number	Item name	Settings	
101	SELECTION FOR SEARCH DIAL ENABLE	Select how the unit enters the search mode. DIAL: Turning the search dial switches to search mode at all times except during recording/editing. [KEY]: The JOG/SHUTTLE button must be pressed to switch to search mode.	
104	AUDIO MUTING TIME	Select the length of time for which audio muting occurs when the unit switches to playback either from stopped or from still playback in the search mode. (for Betacam or Betacam SP playback only) [OFF]: Set the audio muting time to zero (i.e. no muting). 0.1S to 1.0S: Set the audio muting time from 0.1 second to 1.0 second, in 0.1-second increments.	
105	REFERENCE SYSTEM ALARM	Select whether or not to display a warning when the video/audio reference signal selected by OUT REF on the P2 VIDEO page of the function menu, is not supplied or is out of phase with the input video signal. OFF: No warning. [ON]: Flash the STOP button as a warning.	
107	REC INHIBIT LAMP FLASHING	Select whether or not to flash the REC INHI indicator when the erasure prevention plug on the cassette is pressed in. [OFF]: Do not flash the REC INHI indicator. ON: Flash the REC INHI indicator.	
108	AUTO EE SELECT	When a cassette is inserted and PB/EE on the HOME page of the function menu is set to EE, select the VTR modes in which input video and audio signals are automatically handled in E-E mode. [S/F/R]: In STOP/EJECT/F.FWD/REW modes STOP: In STOP/EJECT modes	
109	FORCED EE WHEN TAPE UNTHREAD	During tape threading and unthreading, and when no cassette is inserted, select whether the setting for PB/EE on the HOME page of the function menu controls the PB/EE setting for output signals. OFF: Control by the function menu item PB/EE [ON]: No control (always E-E signal)	
114	AUDIO MONITOR OUTPUT LEVEL	Select whether the signal output from the AUDIO MONITOR OUTPUT connectors on the rear panel is adjustable with the LEVEL adjustment knob on the front panel. VAR: Adjustable [FIXED]: Not adjustable	
118	KEY INHIBIT SWITCH EFFECTIVE AREA	Select which switches and buttons can be operated when the KEY INHI switch on the front panel is set to ON. The following sub-items control different sets of switches and buttons independently.	
	Sub-item		
	1	REMOTE SELECT	Select whether the REMOTE button on the front panel is enabled. [DIS]: Disabled ENA: Enabled
	2	FUNCTION-KEY	Select whether the function buttons on the front panel are enabled. [DIS]: Disabled ENA: Enabled
3	MODE CONTROL	Select whether the operative buttons and switches on the front panel are enabled. [DIS]: Disabled ENA: Enabled (except the REMOTE button and function buttons)	

Item number	Item name	Settings
120	CTL LOCK IN SHTL	Select whether the tape transport should be phase-locked to the CTL signal during playback in shuttle mode. OFF: Not phase-locked [ON]: Phase-locked
125	AUTO REWIND	Select whether to rewind the tape automatically when recording or playback reaches the end of a tape. DIS: Do not rewind the tape automatically. [ENA]: Rewind the tape automatically.
130	TIMER DISPLAY DIMMER CONTROL	Set the brightness of the display window. 100% [75%] 50% OFF
137	TRACKING CONTROL VIA JOG/SHUTTLE DIAL	Select whether the search dial is enabled for tracking control. [OFF]: Disabled the tracking control ON: Enabled the tracking control during playback
138	STOP CODE FUNCTION	Set for detection of the stop code, and recording to a tape. Note This is enabled in 59.94i, 29.97PsF mode only.
	Sub-item	
	1 STOP ADJUST	Adjust the position to stop the tape when the stop code is detected. [0F] to 30F
2 REC ADJUST	Adjust the position to record the stop code. 1SEC to [3SEC] to 5SEC	
140 ^{a)}	AREA MARKER	Select whether the down-converted SD output signal is displayed in the display window or not or whether the down-convert mode or up-convert mode is displayed in the display window or not. [OFF]: Not displayed ON: Displayed
144	REW SPEED	[MAX]: The tape runs with pinch roller disengaged in rewind mode. This setting enables high-speed rewinding the tape. LIMIT: The tape runs with pinch roller engaged in rewind mode. This setting enables quick changeover between the rewind mode and the other mode.
145	MODE KEY ENABLE DURING RECORDING	Set the mode buttons enabled during recording. [ENA]: All mode buttons are enabled. S&P: Only the STOP and PAUSE buttons are enabled.

a) Not applicable in 24PsF/23.98PsF mode

Items 200 to 299: Settings for the remote control interface

Item number	Item name	Settings
201	PARA RUN	Select whether or not to use synchronized operation for two or more VTRs. [DIS]: No synchronized operation ENA: Use synchronized operation Note To use synchronized operation for two or more VTRs, set item 201 to ENA on all of the VTRs.
212	VIDEO REMOTE CONTROL SELECT	Make settings for the control from the HKDV-900 connected to the VIDEO CONTROL connector (9-pin). Select whether to control the up-converter or down-converter when controlling the image enhancer. [DOWN]: Control the down-converter. UP: Control the up-converter. U&D: Control both the up-converter and down-converter. Note Turning the SETUP dial with the D2 button held down on the HKDV-900 controls the value corresponding to setup menu item 718 (SETUP LEVEL).
214	REMOTE INTERFACE	Select a device which remotely controls this unit. [9PIN]: A device connected to the REMOTE 9P connector SDI: A device connected to the HD SDI connector

Items 300 to 399: Settings for editing

Item number	Item name	Settings
305	SYNC GRADE	When editing in phase-synchronized mode with menu item 004 set to ON, select the target phase synchronization accuracy. [ACCUR]: ±0 frame accuracy ROUGH: ±1 frame accuracy
307	AUTO-DELETION FOR INCONSISTENT DATA	Select what happens when an erroneous edit point is set. [MANU]: A warning is given by flashing the DELETE indicator on the P5 EDIT page of the function menu. Delete an unnecessary edit point, or set it correctly. NEG&E: When inconsistent edit points are set, such as when an OUT point is before an IN point, or when too many edit points are specified, the previously set edit point is deleted. NEG: When inconsistent edit points are set, such as when an OUT point is before an IN point, the previously set edit point is deleted. When more edit points than necessary are specified, the DELETE indicator flashes to give a warning. Note Pressing the function button corresponding to an edit point to be deleted and the DELETE function button simultaneously deletes the edit point. If an erroneous edit point is set (the DELETE indicator is flashing), editing is not executed.
309	SERVO/AV REFERENCE SEL	Select the servo reference signal. [AUTO1]: During recording, the input video signal is used as the servo reference signal. During playback, the signal selected by OUT REF on the P2 VIDEO page of the function menu is used as the servo reference signal. If the signal selected by the OUT REF setting is not connected, an internal reference signal is used. AUTO2: When OUT REF on the P2 VIDEO page of the function menu is set to REF, and ASSEMBLE on the HOME page of the function menu is set to ON, the reference signal for video/audio signal processing is locked to the input video signal. EXT: The servo reference signal is forced to be an external reference video input.
318	EDIT RETRY	For two-VTR editing, set when this unit is used as the recorder. Selects the operation if the recorder was not synchronized in time. OFF: Editing is not carried out, and the unit stops. [ON]: The editing is automatically retried (up to twice).
326	AUTOMATIC IN ENTRY AFTER AUTOEDIT	Select whether or not to automatically set the OUT point of the previous edit as the next IN point at the end of an automatic edit. [OFF]: No automatic setting R: Set recorder IN point automatically. R & P: Set recorder IN point automatically, and also player IN point in two-VTR editing.
334	EE REFERENCE CONTROL	Sets the method to select the reference video signal in E-E mode. [NORMAL]: Select according to the table in “3-5 Setting Reference Video Signals” on page 25. INPUT: Select an input video signal in E-E mode. In other cases, Select according to the table in “3-5 Setting Reference Video Signals” on page 25.

Items 400 to 499: Settings for preroll

Item number	Item name	Settings
401	FUNCTION MODE AFTER CUEUP	Select the state that the unit goes into after a cuing-up operation. [STOP]: Stop (the stop mode) STILL: Still playback (in search mode) Note When controlling this unit from an editor with the standard constants set, select STOP.
402	TIME REFERENCE FOR PREROLL	When prerolling a tape with timecode discontinuity, select whether or not to use CTL pulses to count timecode from before a discontinuity. [CTL]: Use CTL pulses to count timecode. TC: Do not use CTL pulses to count timecode.
403	AUTOMATIC PREROLL REFERENCE ENTRY	Select whether or not the IN point is automatically set by pressing the PREROLL button, when the IN point is not set before starting preroll. [DIS]: IN point is not set automatically. ENA: IN point is set automatically.
405	CUEUP BY CTL	Select the tape transport mode when cuing. This setting is valid only when CTL/TC on the HOME page of the function menu is set to CTL. [CAP]: During cuing up, the tape transport is in the pinch ON state (maximum tape speed 10 times normal). REEL: During cuing up, the tape transport is in the pinch OFF state. As the tape approaches the cue up point and the tape speed drops, the tape transport switches to the pinch ON state. ^{a)} To give priority to editing accuracy, select CAP.

a) When controlling with an editor such as a BVE-2000, select REEL for quick cueup.

Items 500 to 599: Settings for tape protection

Item number	Item name	Settings
501	STILL TIMER	Select the time delay from the tape transport stopping (either the stop mode or the still playback mode in search mode) until the unit automatically switches to the tape protection mode, in order to protect the video heads and the tape. 0.5S to [8M] to 30M: Set the value in the range 0.5 seconds to 30 minutes.
502	TAPE PROTECTION MODE FROM SEARCH	Select the operation of the protection mode to protect the video heads and tape when in the still playback mode in search mode (jog/shuttle). [STEP]: Step forward at 0.2 time of the normal speed for 0.2 second. STDBY: Switch to Standby OFF mode (the unit not on standby). T.REL: Switch to tension release mode (the tape tension slackened).
503	TAPE PROTECTION MODE FROM STOP	Select the operation of the protection mode to protect the video heads and tape when stopped (the stop mode). [STDBY]: Switch to Standby OFF mode (the unit not on standby). T.REL: Switch to tension release mode (the tape tension slackened). STEP: Step forward at 0.2 time of the normal speed for 0.2 second.

Items 600 to 699: Settings for a timecode generator

Item number	Item name	Settings
601	VITC POSITION SEL-1	<p>In 59.94i/29.97PsF mode Select a line to insert the VITC in. (For SD output) 12H to [16H] to 20H: Select any line from 12 to 20.</p> <p>Note You can insert the VITC signal in two places. To insert it in two places, set both items 601 and 602.</p>
		<p>In 50i/25PsF mode Select a line to insert the VITC in. (For SD output) 9H to [19H] to 22H: Select any line from 9 to 22.</p> <p>Note You can insert the VITC signal in two places. To insert it in two places, set both items 601 and 602.</p>
602	VITC POSITION SEL-2	<p>In 59.94i/29.97PsF mode Select a line to insert the VITC in. (For SD output) 12H to [18H] to 20H: Select any line from 12 to 20.</p> <p>Note You can insert the VITC signal in two places. To insert it in two places, set both items 601 and 602.</p>
		<p>In 50i/25PsF mode Select a line to insert the VITC in. (For SD output) 9H to [21H] to 22H: Select any line from 9 to 22.</p> <p>Note You can insert the VITC signal in two places. To insert it in two places, set both items 601 and 602.</p>
603	ID CODE PRESET	<p>Select whether or not to set the ID code. [OFF]: Do not set the ID code. ON: Set the ID code.</p> <p>To set the ID code: Display this item in the display window, and press the SET function button. The ID code setting mode is obtained. Select the digit to be set by pressing the ← or → function button. When you select all digits, set the SET function button again. The ID code is stored and the ID code setting mode is terminated.</p>
604	ID CODE SW	<p>Select whether or not to record the ID code set using item 603 in the user bits. [OFF]: Record the normal data in the user bits. ON: Record the ID code in the user bits.</p>
605	TCG REGEN MODE	<p>Select the signal to be regenerated when the timecode generator is in the regeneration mode (when the PRST/RGN on the P4 TC page of the function menu is set to LTC or VITC). [TC&UB]: Both the timecode and user bits are regenerated. TC: Only the timecode is regenerated. UB: Only the user bits are regenerated.</p>
606	TC OUTPUT SIGNAL IN REGEN MODE	<p>Select the signal output from the TIME CODE OUT connector during normal (x1) speed playback. [TAPE]: During tape playback, the playback timecode signal is output without regeneration. REGEN: The playback timecode is output after regeneration.</p>
607	U-BIT BINARY GROUP FLAG	<p>Select the user bits to be used in the timecode generated by the timecode generator. [000]: Character set not specified 001: 8-bit characters compliant with ISO 646 and ISO 2022 010: Undefined 011: Undefined 100: Undefined 101: SMPTE 262M page/line multiplex system 110: Undefined 111: Undefined</p>

Item number	Item name	Settings
608	PHASE CORRECTION	Select whether or not to carry out phase correction control on the LTC generated by the timecode generator. [OFF]: No control ON: Carry out control
610	REGEN CONTROL MODE	Select whether or not the timecode is automatically regenerated. AE&PR: In automatic editing in assemble mode or back space editing with this unit as the recorder, regardless of the settings of TCG and PRST/RGN on the P4 TC page of the function menu, the timecode generator regenerates according to the timecode on the tape. MANU: Regardless of whether this unit is the recorder or player, the timecode generator operates in accordance with the settings of TCG and PRST/RGN on the P4 TC page in function menu. [FULL]: Whether local or remote and regardless of the settings of TCG and PRST/RGN on the P4 TC page in function menu, when ASSEMBLE on the HOME page is set to ON or when back space editing is to be performed, the timecode generator regenerates according to the timecode played back from the tape.
614	FIRST EDIT TC	In First Edit mode, select whether or not to set the timecode value for the start when creating the base tape for editing. When this is set to ON, set the start timecode value. <i>For setting the start timecode, see setup menu item 603 on page 68.</i> OFF: Do not set. ON: Set.
615	FIRST EDIT HEADER	Set the number of seconds before the timecode value set by setup menu item 614 at which the recording starts. 10S to [20S] to 30S: Set value in this range, in increments of 1 second
617	LTC OUTPUT PHASE SELECT	Set the output phase of timecode signals (LTC). [TCG/R]: Output the playback timecode signal during playback. When the edit preset function is on or when recording, output the timecode signal generated by the internal timecode generator. INPUT: Use the same phase as the input video. OUTPUT: Use the same phase as the output video. AUTO: Use the same phase as the input video when editing, and use the same phase as the output video at other times (playback, recording, etc.).
618	UPCONV EMBEDDED VITC	Select the source timecode for HD-SDI embedded VITC which is output after subjected to up-conversion during playback of SD-format tape. [VITC]: Select VITC recorded on SD-format tape. LTC: Select LTC recorded on SD-format tape.
620	TC CONVERT 24F → 25F (in 50i or 25PsF mode only)	Select whether to convert playback timecode to 25F timecode during playback of tape recorded in 24PsF or 23.98PsF mode. [OFF]: Do not convert timecode. ON: Convert timecode.
	TC CONVERT 25F → 24F (in 24PsF, 23.98PsF mode only)	Select whether to convert playback timecode to 24F timecode during playback of tape recorded in 25i or 25PsF mode. [OFF]: Do not convert timecode. ON: Convert timecode.
621	24F STARTING TC SEL (in 50i or 25PsF mode only)	Select whether the 24F starting timecode is set or not for timecode conversion from 24F to 25F. [OFF]: Do not set the starting timecode. ON: Set the starting timecode. To set the 24F starting timecode Press the F5 (SET) button with this menu item displayed in the menu display to enter the starting timecode setting mode. You can then set the user starting timecode digit by digit using the F3 (←) button and F4 (→) buttons for digit selection. When all required digits have been set correctly, press the F5 (SET) button again to save the starting timecode and exit from the ID code setting mode.

Item number	Item name	Settings	
	25F STARTING TC SEL (in 24PsF, 23.98PsF mode only)	Select whether the 25F starting timecode is set or not for timecode conversion from 25F to 24F. [OFF]: Do not set the starting timecode. ON: Set the starting timecode. To set the 25F starting timecode Press the F5 (SET) button with this menu item displayed in the menu display to enter the starting timecode setting mode. You can then set the user starting timecode digit by digit using the F3 (←) button and F4 (→) buttons for digit selection. When all required digits have been set correctly, press the F5 (SET) button again to save the starting	
622	24F JUMPING TC SEL (in 50i or 25PsF mode only)	Select one of the following setting for timecode conversion from 24F to 25F. [-3H]: Set JUMPING TC to "STARTING TC -3H" -2H: Set JUMPING TC to "STARTING TC -2H" -1H: Set JUMPING TC to "STARTING TC -1H" +1H: Set JUMPING TC to "STARTING TC +1H" +2H: Set JUMPING TC to "STARTING TC +2H" +3H: Set JUMPING TC to "STARTING TC +3H" 0H: Set JUMPING TC to "STARTING TC -1 frame"	
	25F JUMPING TC SEL (in 24PsF, 23.98PsF mode only)	Select one of the following setting for timecode conversion from 25F to 24F. [-3H]: Set JUMPING TC to "STARTING TC -3H" -2H: Set JUMPING TC to "STARTING TC -2H" -1H: Set JUMPING TC to "STARTING TC -1H" +1H: Set JUMPING TC to "STARTING TC +1H" +2H: Set JUMPING TC to "STARTING TC +2H" +3H: Set JUMPING TC to "STARTING TC +3H" 0H: Set JUMPING TC to "STARTING TC -1 frame"	
630	SEARCH TYPE SELECT	[ALL]: Searching for all shot mark in index search operation REC: Searching for rec start mark in index search operation SHOT 1: Searching for shot mark 1 in index search operation SHOT 2: Searching for shot mark 2 in index search operation POST: Searching for post mark in index search operation STOP^{a)}: Searching for the stop code in index search operation	
631	REC START MARK MODE		
	Sub item		
	1	CRASH REC	[OFF]: Not recording the rec start mark ON: Recording the rec start mark in normal recording.
	2	ASSEMBLE	[OFF]: Not recording the rec start mark ON: Recording the rec start mark in assemble editing.
	3	PAUSE REC	[OFF]: Not recording the rec start mark ON: Recording the rec start mark in back space editing.
651	UMID OUTPUT	Select UMID data output. [OFF]: Do not output UMID. BASIC: Output Basic UMID. EXTND: Output Extended UMID. Note Even if EXTENDED is selected, Basic UMID is output if Basic UMID is recorded on the tape being played back.	
653	UMID HD VANC LINE	Specify the HD SDI signal VANC line into which the UMID should be inserted. 9H to [17H] to 20H Note The output VANC line during playback follows the setting for recording.	
654	UMID GENERATE METHOD	Select the Instance No. generation method when the UMID is inherited. [16BIT]: Copy No. + 16-bit random number 24BIT: 24-bit random number Note When menu item 656 is set to NEW (an Instance Number indicating that this is the original is generated), the same value (all zeros) is generated regardless of which of the above methods is selected.	

Item number	Item name	Settings
655	UMID RECORDING	Select the UMID type to be recorded to tape. [OFF]: Do not record UMID. BASIC: Record Basic UMID. EXTND: Record Extended UMID.
656	MATERIAL NO.	Select whether to inherit the UMID in the input signal when recording a UMID. [INPUT]: Inherit the UMID in the input signal, if it is present. <ul style="list-style-type: none"> •Even when INPUT is selected, a new UMID is generated if the input signal does not contain UMID data (the same behavior as when NEW is selected). •When recording with inherited data, the Instance Number is newly generated according to menu item 654, changing to a value that indicates that “this is a copy.” •When the UMID in the input signal is a Basic UMID, a Basic UMID is recorded, even if menu item 655 is set to EXTENDED. •When the UMID in the input signal is an Extended UMID, the recorded UMID follows the setting for setup menu item 655. NEW: Generate a new UMID, regardless of whether or not the input signal contains a UMID. <ul style="list-style-type: none"> •The Basic section does not change during recording. •An Instance Number indicating that “this is the original” is generated. •The Source Pack Date/Time (when) changes with each frame. •The Source Pack Spatial Co-ordinates (where) are not recorded. •The Source Pack Stored Ownership (who) can be set. (See “ Setting Stored Ownership” on page 54.)

a) Not applicable in 59.94i/29.97PsF mode

Items 700 to799: Settings for video control

Item number	Item name	Settings	
703 ^{a)}	BLANK LINE SELECT	Switch blanking on or off for individual lines in the vertical blanking interval of the SD video signal. The Y/C signal and odd/even fields are blanked simultaneously. [- -]: Specify the blanking for each line separately. BLANK: Regardless of the setting for other sub-items, blank all lines which can be specified in this menu item. THROU: Regardless of the setting for other sub-items, switch off blanking for all lines which can be specified in this menu item.	
	Sub-Item		
	0 ALL LINE		
	In 59.94i/29.97PsF mode		
	12 to 20	LINE12 to LINE20	Specify blanking for lines 12 to 20. [BLANK]: Carry out blanking. THROU: Switch off blanking.
	21	LINE 21	Specify blanking for lines 21. [BLANK]: Carry out blanking. HALF: Carry out half-blanking. THROU: Switch off blanking.
	In 50i/25PsF mode		
	9 to 22	LINE 9 to LINE 22	Specify blanking for lines 9 to 22. [BLANK]: Carry out blanking. THROU: Switch off blanking.
23	LINE 23	[HALF]: Carry out half-blanking. THROU: Switch off blanking.	
705 ^{a)}	EDGE SUBCARRIER REDUCER MODE	During playback of an SD tape, in the playback circuit the edge subcarrier reducer (ESR) is automatically switched on or off according to the VTR operation. When playing an SD tape with a Non-Standard signal recorded, for example, if the color edges are not as good as with a proper signal, the ESR can be forced on. This item makes this selection. [AUTO]: ESR is switched on and off automatically. ON: ESR operation is forced on.	

Item number	Item name	Settings
710	INTERNAL VIDEO SIGNAL GENERATOR	Select the test signal to be generated by the internal test signal generator. OFF : No test signal is generated. (The VTR operates normally.) [CB75] : Color bar signal MLTBS : Multi-burst signal 10STEP : 10-step signal PLSBR : Pulse and bar signal RAMP : Ramp signal BLACK : Black signal MCB : Multi color bar signal To generate the test signal, set this item other than OFF, and press the VIDEO IN function button for more than three seconds on the P2 VIDEO page of the function menu. VIDEO IN is set to SG, and a test signal is generated. Pressing the VIDEO IN function button again stops the generation of a test signal.
713	VIDEO SETUP REFERENCE LEVEL (in 59.94i/29.97PsF mode only)	Set the video setup amount to be removed from the Betacam playback signal and to be added to the composite output signal.
	Sub-Item	
	0 MASTER LEVEL	When BETACAM PB LEVEL and OUTPUT LEVEL is set to MASTER, the setup amount selected with this item is removed from the Betacam playback signal and added the same amount to the output signal. [0.0%], 7.5%
	1 BETACAM PB LEVEL	[MASTER] : Set the Betacam playback signal to master. 0.0%, 7.5% : Set the setup amount to be removed from the Betacam playback signal.
2 OUTPUT LEVEL	[MASTER] : Set the output signal to master. 0.0%, 7.5% : Set the setup amount to be added to the output signal.	
715 ^{a)}	VIDEO GAIN CONTROL	Adjust the video output level of an SD output signal. 0 to [800H] to B50H
716 ^{a)}	CHROMA GAIN CONTROL	Adjust the chroma output level of an SD output signal. 0 to [800H] to B50H
717 ^{a)}	CHROMA PHASE CONTROL	Adjust the chroma phase of an SD output signal. 0 to [80H] to FFH
718 ^{a)}	SETUP LEVEL	Adjust the SD setup level (black level) of an SD output signal. 0 to [110H] to 220H
719 ^{a)}	SYSTEM PHASE SYNC	Adjust the sync phase of an SD output signal. 0 to [80H] to FFH
720 ^{a)}	SYSTEM PHASE SC	Adjust the subcarrier phase of an SD output signal. [0] to 3FFH
721 ^{a)}	Y/C DELAY	For playback of an analog Betacam cassette, adjust the Y/C delay. 0 to [800H] to FFFH
726 ^{a)}	H BLANKING WIDTH	Select the horizontal blanking width of the video output signal. [NARROW] : Digital blanking (narrow) [WIDE] : Analog blanking (wide) When WIDE is selected, the horizontal blanking width complies with RS170A, and normally the blanking is widened and the image becomes narrower. It is recommended to select NARROW at the editing stage, then later, for broadcast transmission to select WIDE, to output a signal conforming to the standard.
727	VIDEO EDIT PREVIEW SWITCHER	Set the output phase for the video playback signal when ASSEMBLE on the HOME page of the function menu is set to ON. [INT] : The output phase of the video playback signal is the same as the output phase in E-E mode. Use this setting when editing with a single VTR, or when previewing while watching the VTR output signal. EXT : The output phase of the video playback signal is the same as the phase of an input video signal or external reference signal.
728	OUTPUT SCH PHASE	Adjust the subcarrier H phase. 0 to [800H] to FFFH

Item number	Item name	Settings
740	MASTER LEVEL (HD)	Adjust the high-definition video signal output from the HD SDI OUTPUT connector. This adjusts the Y, PB, and PR levels simultaneously. 0.0% (0H) to [100% (800H)] to 141.3% (B4EH)
741	Y LEVEL (HD)	Adjust the Y level of the high-definition video signal output from the HD SDI OUTPUT connector. 0.0% (0H) to [100% (800H)] to 141.3% (B4EH)
742	PB LEVEL (HD)	Adjust the PB level of the high-definition video signal output from the HD SDI OUTPUT connector. 0.0% (0H) to [100% (800H)] to 141.3% (B4EH)
743	PR LEVEL (HD)	Adjust the PR level of the high-definition video signal output from the HD SDI OUTPUT connector. 0.0% (0H) to [100% (800H)] to 141.3% (B4EH)
745	SETUP (BLACK) LEVEL (HD)	Adjust the setup level of the high-definition video signal output from the HD SDI OUTPUT connector. 0 to [110H] to 220H
746	SYNC PHASE (HD)	Control the H sync phase of the high-definition video signal output from the HD SDI OUTPUT connector according to the menu. 0 to [80H] to FFH
747	FINE (HD)	Fine control the H sync phase of the high-definition video signal output from the HD SDI OUTPUT connector according to the menu. [0] to 3FFH

a) Not applicable in 24PsF/23.98PsF mode

Note

When you set setup menu items 715 through 718, 721, and 740 through 747, set VID.PROC on the P1 PROCS page of the function menu to MENU. Then the video output control function on the front panel is disabled.

Items 800 to 899: Settings for audio control

Item number	Item name	Settings
802	DIGITAL AUDIO MUTING IN SHUTTLE MODE	Set the digital audio muting conditions during shuttle playback. [OFF]: Not muted. CUEUP: Muted during cue-up or preroll operations. FULL: Muted in shuttle mode. SLOW: Muted, with the speed less than ± 0.2 time normal playback.
807	AUDIO OUTPUT PHASE	Select the output timing of digital audio playback signals (HD SDI, and SDI only). The reference position corresponds to a setting for 80H; when the setting is less than 80H, the output timing is advanced, and when it is higher than 80H, the output timing is delayed. (at 80H, 128 samples = approx. 2.7 ms, and 1 sample=approx. 20 μ s) 0 to [80] to FF: Setting in this range
808	INTERNAL AUDIO SIGNAL GENERATOR	Select the operation of the internal audio test signal generator. OFF: No operation SILNC: Silent signal [1KHZ]: At 1 kHz, -20 dB FS sine wave is supplied to all audio input channels.
810	AUDIO EDIT PREVIEW SWITCHER	Set the output phase for the audio playback signal when ASSEMBLE is set to ON. [INT]: The audio playback signal output phase is the same as the output phase in E-E mode. Use this setting when editing with a single VTR, or when previewing while watching the VTR output signal. EXT: The audio playback signal output phase is the same as the phase of an input video signal or external reference video signal.
812	AUDIO OUTPUT LEVEL	Set the audio output level. [+4 dB] 0 dB -3 dB -20 dB Note -20 dB is not displayed in the display window.

Item number	Item name	Settings
823	NAU FLG PB	Controls the non-audio flag when the playback format is Betacam SX.
	Sub-item	
	1 CH1/CH2	During Betacam SX playback, sets the non-audio flag of a digital audio output as follows. [OFF]: OFF (the data is audio) ON: ON (the data is non-audio) Notes <ul style="list-style-type: none"> • During playback of analog tapes, the non-audio flag is OFF regardless of the setting for this item. • In the HDCAM format, the non-audio flag follows the setting for maintenance menu item M372 during recording and in E-E mode. During playback, it follows the setting recorded on the tape. <i>For details on the maintenance menu item M372, refer to the Maintenance Manual.</i>
2	CH3/CH4	
824	ANALOG LINE OUTPUT SELECT	Select audio channels output from the AUDIO OUTPUT connectors on the rear panel. [CH1/2]: Output the audio channels 1 and 2. CH3/4: Output the audio channels 3 and 4.
826	AUDIO VOLUME SELECT	Assign the audio channels to the REC LEVEL adjustment knobs and PB LEVEL adjustment knobs on the front panel. [CH1/2]: Assign the audio channels 1 and 2. CH3/4: Assign the audio channels 3 and 4. 1(3)/2(4): Assign the audio channels 1/3 and 2/4. REC4: Assign the audio channels 1 to 4 for recording. PB4: Assign the audio channels 1 to 4 for playback.
832	ANALOG AUDIO INPUT MODE	Select the signal recorded on audio channels 3 and 4 when an analog audio input is selected. [OFF]: No recording PARA: Recording channel 1 on channel 3, and channel 2 on channel 4
833	CUE AUDIO INPUT SELECT	Select the digital audio channel recorded on cue channel. OFF: No recording CH1+2: Recording audio channels 1 and 2 CH3+4: Recording audio channels 3 and 4 [CH1]: Recording audio channel 1 CH2: Recording audio channel 2
834	AUDIO INPUT LEVEL	Set the analog audio input.
	Sub-item	
	1 CH1	[LINE]: line input
	2 CH2	MIC: microphone input
3	LINE LEVEL	Set the line input level. [+4 dB] 0 dB -3 dB -20 dB
835	CUE REC LEVEL ATT	Set the recording level on the cue track. 0 dB [-3 dB] -6 dB -9 dB -12 dB
836	DIGITAL AUDIO MUTING IN FF/REW MODE	Select whether the playback sound is muted in fast forward or rewind mode if the playback format is HDCAM or Betacam SX. OFF: The playback sound is not muted. [ON]: The playback sound is muted.

Items 900 to 999: Settings for digital processing

Item number	Item name	Settings
901	VIDEO OUTPUT DATA	Set the bit length for SD-SDI video output data. 8bit : Set the bit length to 8 bits. [10bit] : Set the bit length to 10 bits. It is recommended that you select the optimal setting for the device to which you are going to connect this unit.
920	SD-SDI RP188 ATC CONTROL	Select whether or not to add information to the SDI output. OFF : Select whether to add (ON), or not (OFF). [ON] : Add RP-188 timecode data.
921	ASPECT FLAG	Add the 16:9/Squeeze identification signal specified by ARIB TR-B17 to the down-converted SD output when an HDCAM tape is played. When an SD tape is played, the 16:9/Squeeze identification signal is detected, and switching the up-converter mode is set. [OFF] : The 16:9/Squeeze identification signal is not added to the down-converted SD output from the HD signal. When an SD tape is played, the up-converter mode depends on the setting for setup menu item 950 independent of the existence of the identification signal on the tape. ON : The 16:9/Squeeze identification signal is added to the down-converted SD output in squeeze mode from the HD signal. When an SD tape is played, the identification signal on the tape is detected, and the up-converter mode is automatically selected. If the identification signal on the tape is not detected, the up-converter mode depends on the setting for setup menu item 950.
930	DOWN CONVERTER MODE (DC)	Select the down-converter mode. [CROP] : Select the edge-crop mode. L-BOX : Select the letter box mode. SQUEZ : Select the squeeze mode.
931	DOWN CONVERTER LETTER BOX MODE (DC)	Select the aspect ratio of the down-converter output when menu item 930 is set to LETTER BOX. [16:9] : Set the aspect ratio of the HD-SD converter output to 16:9. 14:9 : Set the aspect ratio of the HD-SD converter output to 14:9. 13:9 : Set the aspect ratio of the HD-SD converter output to 13:9.
932	H CROP POSITION (DC)	Adjust the H-crop (the horizontal position when cropping in the edge crop mode) of the down converter output when menu item 930 is set to EDGE-CROP. -120 to [0] to 120
934	CROSS COLOR (DC)	Adjust the down-converter cross color. 0 to [8] to 15
935	DETAIL GAIN (DC)	Adjust the down-converter image enhancer, the sharpness of edge emphasis. 0 to [20H] to 7FH
936	LIMITER (DC)	Adjust the down-converter image enhancer, the maximum detail level added to emphasize the original signal. 0 to [20H] to 3FH
937	CRISP THRESHOLD (DC)	Adjust the down-converter image enhancer, the threshold amplitude at which low amplitude signals are not emphasized. [0] to FH
938	LEVEL DEPEND THRESHOLD (DC)	Adjust the down-converter image enhancer. Set the luminance range for edge enhancement. 0 to [8] to FH
939	H DETAIL FREQUENCY (DC)	Adjust the down-converter image enhancer. Set the central frequency for edge enhancement. 2.6MHz to 3.4MHz to [3.9MHz] to 4.6MHz
940	H/V RATIO (DC)	Adjust the down-converter image enhancer. Set the horizontal/vertical ratio for edge enhancement. 0 to [3] to 7
941	GAMMA LEVEL (DC)	Adjust the down-converter image enhancer, the slope of the correction curve. 0 to [80H] to 100H
942	V FILTER SELECT	Set the vertical interpolation filter coefficient for down-converter output. The vertical resolution increases as the setting grows larger. [1] to 3

Item number	Item name	Settings	
943	CROSS COLOR CRISP	Set the cross color crisp level for down-converter output. 0 to [4] to FH	
950	UP CONVERTER MODE (UC)	Select the up-converter mode. [CROP]: Select the edge-crop mode. L-BOX: Select the letter box mode. SQUEZ: Select the squeeze mode.	
951	H CROP POSITION (UC)	Adjust the H-crop (the horizontal position when inserting in the edge crop mode) of the up/down converter output when menu item 950 is set to EDGE-CROP. -120 to [0] to 120	
952	LETTER BOX POSITION (UC)	Adjust the vertical position of the letter box mode cutout in up-converter output when LETTER BOX is selected in menu item 950. -120 to [0] to 120	
953	UP CONVERTER PROCESS SELECT	Select the original picture to use when converting SD to HD. FIELD: Use a field picture. FRAME: Use a frame picture. [ADAPT] (standard mode): Set the ratio of converting from frames or fields to the standard ratio when up-converting. ADAP2 (still picture priority mode): Set the ratio of converting from frames higher when up-converting. ADAP3 (motion priority mode): Set the ratio of converting from fields higher when up-converting.	
954	DETAIL GAIN (UC)	Adjust the up-converter image enhancer, the sharpness of edge emphasis. 0 to [40H] to 7FH	
955	LIMITER (UC)	Adjust the up-converter image enhancer, the maximum detail level added to emphasize the original signal. 0 to [20H] to 3FH	
956	CRISP THRESHOLD (UC)	Adjust the up-converter image enhancer. Set the threshold amplitude at which low amplitude signals are not emphasized. 0 to [8] to FH	
957	LEVEL DEPEND THRESHOLD (UC)	Adjust the up-converter image enhancer. Set the luminance range for edge enhancement. 0 to [8] to FH	
958	H DETAIL FREQUENCY (UC)	Adjust the up-converter image enhancer. Set the central frequency and frequency characteristic for edge enhancement. 3.2MHz: 3.2 MHz \pm 1.1 MHz 4.5MHz: 4.5 MHz \pm 1.4 MHz [5.0MHz]: 5.0 MHz \pm 0.7 MHz 4.0MHz: 4.0 MHz \pm 2.0 MHz	
959	H/V RATIO (UC)	Adjust the up-converter image enhancer. Set the horizontal/vertical ratio for edge enhancement. 0 to [3] to 7	
960	GAMMA LEVEL (UC)	Adjust the up-converter image enhancer, the slope of the correction curve. 0 to [80H] to 100H	
961	BACKGROUND COLOR (UC)	Set the color of the background (no material part) when up-converting.	
	Sub-item		
	1	BG COLOR	Set the color. [BLACK]: Black GRAY: Gray BLUE: Blue TABLE: Use the TABLE settings.
	2	Y TABLE	Adjust the Y level of the background. [0] to FFH
	3	B-Y TABLE	Adjust the B-Y level of the background. 0 to [80] to FFH
4	R-Y TABLE	Adjust the R-Y level of the background. 0 to [80] to FFH	

10-1 Removing a Cassette When Tape Slack Occurs

If tape slack occurs in the unit, it is necessary to remove the upper lid and sound baffle. This job should always be entrusted to a technician who has undergone service training.

For details, refer to the Installation Manual.

10-2 Head Cleaning

To clean the video heads and audio heads, always use the special-purpose Sony BCT-HD12CL cleaning cassette. If you insert the cleaning cassette, it is automatically ejected after a head cleaning operation which lasts for 10 seconds.

Follow the instructions with the cleaning cassette carefully, as inappropriate use of the cleaning cassette can damage the heads.

Note

You cannot use the BCT-5CLN cleaning cassette.

10-3 Error Messages

This unit is equipped with a self-diagnosis function, and if a problem is detected, displays an error message in the time data display and on the monitor.

If an error message appears, contact your Sony service representative.

Indications in the time data display

If a problem is detected, the ALARM indicator lights in the display window, and an error code appears in time data display area.



Indications on the monitor

The error message and code also appear superimposed on a monitor connected to the COMPOSITE OUT 2 (SUPER) connector, HD SDI OUTPUT (SUPER) connectors, or SDI OUT 2 (SUPER) connector. Depending on the error code, an indication of the source of the problem may appear as a secondary error message.

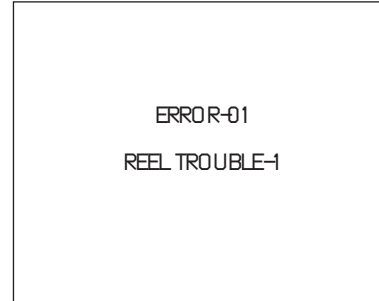

Error message displays

- To display error messages and codes superimposed on the monitor, set the CHARACTER on the HOME page of the function menu to ON.
- Some error messages have no associated error codes. In this case, they appear in the time data display.
- Error messages with error codes are saved in NV-RAM (non-volatile memory) as an error log.
- In some cases the error message is slightly different on the monitor and in the time data display.

Error Message List

Code	Message	Description
01	REEL TROUBLE	Tape slacking has been detected in the threading or unthreading operation.
02	REEL TROUBLE	Tape slacking or tape breaking has been detected in the SEARCH, FF, or REW mode.
03	REEL TROUBLE	Tape slacking, tape breaking, or supply or take-up reel locking has been detected in the REC or PLAY mode.
04	REEL TROUBLE	A malfunctional tape transport speed has been detected in the FF or REW mode.
05	REEL TROUBLE	A malfunctional operation of the supply or take-up reel has been detected during cassette insertion.
06	TAPE TENSION	Excessive tape tension has been detected in the REC or PLAY mode.
07	CAPSTAN TROUBLE	Malfunction of capstan motor has been detected.
08	DRUM TROUBLE	Malfunction of drum motor has been detected.
09	TH/UNTH MOTOR	Malfunction of threading or unthreading operation has been detected.
0A	THREADING	The tape top processing has not been completed in the threading mode.
10	HUMID	Dew condensation has been detected.
12	TAPE TOP SENSOR	Malfunction of tape top sensor has been detected.
13	TAPE END SENSOR	Malfunction of tape end sensor has been detected.
14	FAN MOTOR	Malfunction of cooling fan motor has been detected.
20	CASS COMP MOTOR	Malfunction of cassette compartment-up or down operation has been detected.
92	INTERNAL I/F1	Abnormality in the interface between SYS CPU (on SY-320 board) and SYS NV-RAM (SY-320 board) has been detected.

Code	Message	Description
96	SY NV-RAM ERROR	Abnormality has been detected in the operation of an NV-RAM (on SY-320 board) for the system control system.
97	SV NV-RAM ERROR	Abnormality has been detected in the operation of an NV-RAM (on SV-225 board) for the servo system.
98	NV-RAM ERROR	Abnormality has been detected in the operation of an NV-RAM (on EQ-101 board) for the RF system or an NV-RAM (on DM-123 board) for the DM system.
99	INTERNAL I/F 2	Abnormality in the interface between SYS CPU (on SY-320 board) and SERVO CPU (on SV-225 board) or MPU (on EQ-101, DM-123, HPR-14, VPR-92, APR-70, and KY-571 board) has been detected.

10-4 Warning Messages

If the unit detects abnormal status that has been set to be detected, the warning mark flashes at the right bottom in the display window. Even if the warning mark is flashing, you can operate the unit. When you press the MENU button together with the SHIFT button, a warning message appears in the display window. The warning message is stored in the error logger menu.

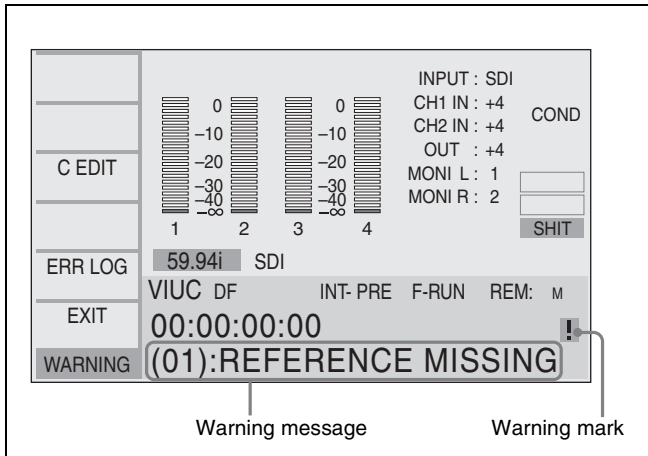

Setting the warning message to be detected

- 1 Press the MENU button together with the PAGE button.
The WARNING screen appears.
- 2 Press the C EDIT function button.
- 3 Turn the MULTI CONTROL knob to display an item to be detected in the display window.

On the video monitor screen, move * to an item to be detected.

- 4 Press the ON/OFF function button to go out OFF.
- 5 Press the SAVE function button.

The setting is stored, and the set message will be detected.

Canceling detecting warning messages

Select a warning message to be cancelled, and press the ON/OFF function button to display OFF.

Warning messages

Message	Description
REFERENCE MISSING	No reference signal is input.
LOST LOCK	Capstan servo lock is released during playback, recording or editing.
NO VIDEO INPUT REC	No video signal is detected during recording.
ASYNCHRONOUS VIDEO REC	Phase difference of the video input signal and reference signal exceeds the allowable range during recording.
APR HARD AU MUTING	An audio signal is muting because of unlocking of PLL in an audio circuit.
HD TG UNLK AU MUTING	An audio signal is muting because of unlocking of PLL of the HD timing generator.
SD TG UNLK AU MUTING	An audio signal is muting because of unlocking of PLL of the SD timing generator.
NO RF AU MUTING	An audio signal is muting because data on a tape cannot be read.
AUX DATA AU MUTING	An audio signal is muting because of incorrect system frequency.

10-5 Moisture Condensation

When the unit is suddenly moved from a cold to a warm location, or used in a very humid place, moisture from the air can condense on the head-drum. This is called moisture condensation. If the tape is run in this state, it can adhere to the drum. To prevent such a condition from occurring, the unit is provided with a moisture detecting function.

If moisture condenses on the head-drum while the unit is in use, the ALARM indicator lights and ERR-10 is displayed in time data display area 1.

If this happens, the drum and capstan motors stop and the cassette is automatically ejected. Then, the drum starts to rotate again to dry its surface. In this state, the unit is not operable. When the moisture has evaporated, the error message disappears and the ALARM indicator goes off.

If ERR-10 appears and the ALARM indicator lights immediately after powering the unit on

Leave the unit powered on and wait until the error message disappears and the indicator goes off.

While the indicator is lit, you cannot insert a cassette.

When the indicator goes off and the error message disappears, you can use the unit.

If you move the unit from a cold to a warm location

Leave the unit powered off for about 10 minutes, in order to give the unit time to detect moisture condensation.

10-6 Regular Checks

10-6-1 Digital Hours Meter

The digital hours meter can display seven items of information, in corresponding display modes, about the operational history of the unit. Use it as a guide in scheduling periodic maintenance.

Display modes of the hours meter

H01: OPERATION mode

Displays the total number of hours the unit has been powered on in units of 1 hour.

H02: DRUM RUNNING mode

Displays the total number of hours the drum has run with tape threaded in units of 1 hour.

H03: TAPE RUNNING mode

Displays the total number of hours the unit has been in fast forward, rewind, playback, search, recording or editing (except for stop and still) mode in units of 1 hour.

H04: THREADING mode

Displays the total number of times tape has been threaded in the unit.

H12: DRUM RUNNING mode (resettable)

Same as H02 except that the count is resettable.

This can be used as a guide in determining when to replace the drum.

H13: TAPE RUNNING mode (resettable)

Same as H03 except that the count is resettable.

This can be used as a guide in determining when to replace such components as fixed heads and pinch rollers.

H14: THREADING mode (resettable)

Same as H04 except that the count is resettable.

This can be used as a guide in determining when to replace, for example, the threading motor.

Displaying the digital hours meter

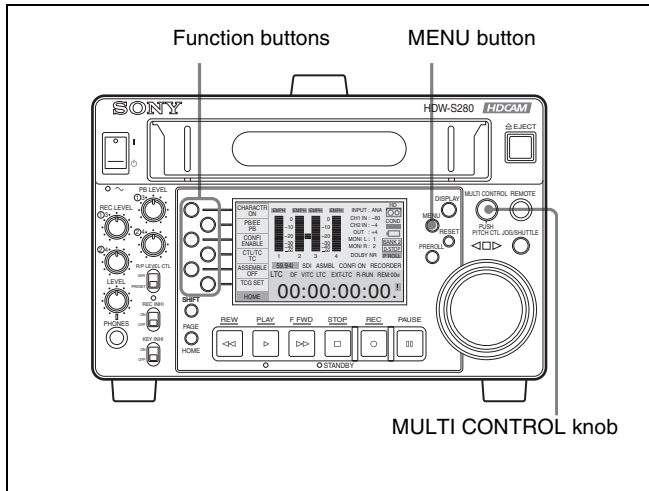

To display the digital hours meter

Press the MENU button, then turn the MULTI CONTROL knob to display the required item in the time data display area.

To exit from the hours meter

Press the EXIT function button.

10-6-2 Maintenance Timings

Use the following table as a timing guide for checking and replacing components of the unit.

These intervals are not guaranteed lifetimes; the timing for replacing components depends on the particular conditions of use. In particular, depending on the degree of dirt

contamination and abrasion, pinch rollers and cleaners may require replacement earlier than suggested by this table.

Note that an arrow in the table means that the component to be replaced is part of the assembly the arrow points to, which must be replaced as a whole.

No.	Replacing components	Mode	Replacement intervals (H)						
			1,000	2,000	3,000	4,000	5,000	6,000	10,000
1	Upper drum assembly	A		R		↓		R	
2	Slip ring	A		R		↓		R	
3	Blush	A		R		↓		R	
4	Drum assembly	A				R			
5	Video head cleaner	B	R	R	R	R	R	R	R
6	Pinch roller	B	R	R	R	R	R	R	R
7	Gear	B		R		R		R	
8	Tension regulator band	B		R		R		R	
9	Timing belt (reel)	B			R			R	
10	S main brake shoe	B			R			R	
11	S reel motor	B						R	
12	Coil spring	C	Replace every 20,000 times						
13	LCD back light	D							R

R: Replace

↓: Replace when the arrowed component is replaced.

Mode A: See menu item H02 or H12 (drum running hours (H))

Mode B: See menu item H03 or H13 (tape running hours (H))

Mode C: See menu item H04 or H14 (threading counter (times))

Mode D: See menu item H01 (operation hours (H))



Menu items

Item No.	Item name	Descriptions
H01	OPERATION HOURS	Total operation hours (H)
H02	DRUM RUNNING HOURS	Total drum running hours (H)
H03	TAPE RUNNING HOURS	Total tape running hours (H)
H04	THREADING COUNTER	Total threading counts (times)
H12	DRUM RUNNING HOURS	Total drum running hours (H) (reset enabled)
H13	TAPE RUNNING HOURS	Total tape running hours (H) (reset enabled)
H14	THREADING COUNTER	Total threading counts (times) (reset enabled)

Appendixes

Specifications

General

Recording format	HDCAM
Power requirements	100 to 240 V AC, 50/60 Hz 12 V DC
Power consumption	AC operation: approx. 0.8A, 80 W
Peak inrush current	(1) Power ON, current probe method: 55 A (240 V), 15 A (100 V) (2) Hot switching inrush current, measured in accordance with European standard EN55103-1: 10 A (230 V)
Operating temperature	5°C to 40°C (41°F to 104°F)
Storage temperature	-20°C to +60°C (-4°F to +140°F)
Operating humidity	25% to 80%
Mass	approx. 6.0 kg (13 lb 4 oz)
Dimensions (w/h/d)	210 × 132 × 425 mm (8 3/8 × 5 1/4 × 16 3/4 inches)

Tape transport system

Tape speed	
HDCAM	96.7 mm/s (59.94i, 29.97PsF) 80.7 mm/s (50i, 25PsF) 77.4 mm/s (24PsF, 23.98PsF)
Betacam SX	59.6 mm/s
Analog Betacam	118.6 mm/s (525/59.94) 101.5 mm/s (625/50)
HDCAM record/playback time	40 minutes with BCT-40HD (59.94i, 29.97PsF) 48 minutes with BCT-40HD (50i, 25PsF) 50 minutes with BCT-40HD (24PsF, 23.98PsF)

Betacam SX playback time	62 minutes with BCT-62SXA
Betacam SP playback time	30 minutes with BCT-30MA (525/59.94) 36 minutes with BCT-30MA (625/50)
Analog Betacam playback time	30 minutes with BCT-30G (525/59.94) 36 minutes with BCT-30G (625/50)
Rewind time	3 minutes or less with BCT-40HD
Fast forward time	4 minutes or less with BCT-40HD
Search speed	Shuttle mode Still to approx. ±10 times normal playback speed (59.94i, 50i) Jog mode Still to ±1.5 times normal playback speed
Servo lock time	HDCAM, SX, SP: 1 second or less (from standby on)
Load/unload time	7 seconds or less
Recommended tapes	HDCAM cassettes (S only): BCT-6HD/12HD/22HD/32HD/ 40HD Betacam SX cassettes (S only) (for playback only) Betacam SP cassettes (S only) (for playback only) Betacam cassettes (S only) (for playback only)

Digital video system

Digital video signal format

Sampling frequency	
HD	Y: 74.25 MHz R-Y/B-Y: 37.125 MHz
SD	Y: 13.5 MHz R-Y/B-Y: 6.75 MHz
Quantization	8 bits/sample
Compression	Coefficient recording system
Channel coding	S-I-NRZI PR-IV
Error correction	Reed-Solomon code 1% or less

Digital audio system

Digital audio (CH1 to CH4) signal format

Sampling frequency	48 kHz (synchronized with video)
Quantization	20 bits/sample
Wow and flutter	Below measurable level
Headroom	20 dB (or 18 dB, 16 dB, 12 dB selectable)
Emphasis	T1= 50 μ s, T2=15 μ s (on/off selectable in recording mode)

Analog input/output (CH1 to CH4)

A/D, D/A quantization	20 bits/sample
Frequency response	20 Hz to 20 kHz +0.5 dB/ -1.0 dB (Standardize at 1 kHz)
Dynamic range	90 dB or more (at 1 kHz, emphasis on)
Distortion	0.08% or less (at 1 kHz, emphasis on, reference level (+4 dBm))
Crosstalk	-80 dB or less (at 1 kHz, between any two channels)

Analog audio (CUE)

Frequency response	100 Hz to 10 kHz, \pm 3 dB
S/N ratio	45 dB or more (at 3% distortion level)
Distortion	2% or less (THD, 1 kHz, reference level)
Wow and flutter	0.3% rms or less

Betacam SX playback

Analog composite output

Bandwidth	0.5 to 5.75 MHz +0.5 dB/-2.0 dB
S/N ratio	53 dB or more
K factor (2T pulse)	1% or less
Differential gain	2% or less
Differential phase	2° or less
Y/C delay	20 ns or less

Digital Audio (CH1 to CH4)

Frequency response	20 Hz to 20 kHz +0.5 dB/ -1.0 dB (Standardize at 1 kHz)
Dynamic range	HDCAM 90 dB or more (at 1 kHz, emphasis on) SX 88 dB or more (at 1 kHz, emphasis on)
Distortion	0.08% or less (at 1 kHz, emphasis on, reference level (+4 dBm))

Analog Betacam playback

Video (525)

		Metal tape	Oxide tape
Band-width	Y	30 Hz to 4.5 MHz +0.5 dB/-4.0 dB	30 Hz to 4.1 MHz +0.5 dB/-6.0 dB
	R-Y/B-Y	30 Hz to 1.5 MHz +0.5 dB/-3.0 dB	30 Hz to 1.5 MHz +0.5 dB/-3.0 dB
S/N ratio	Y	51 dB or more	48 dB or more
	R-Y/B-Y	48 dB or more	45 dB or more
K factor (2T pulse)		2% or less	3% or less
LF non-linearity	Y	3% or less	
	R-Y/B-Y	4% or less	
Y/C delay		20 ns or less	

Video (625)

		Metal tape	Oxide tape
Band-width	Y	20 Hz to 4.5 MHz +0.5 dB/-4.0 dB	25 Hz to 4.1 MHz +0.5 dB/-6.0 dB
	R-Y/B-Y	25 Hz to 1.5 MHz +0.5 dB/-3.0 dB	25 Hz to 1.5 MHz +0.5 dB/-3.0 dB
S/N ratio	Y	48 dB or more	46 dB or more
	R-Y/B-Y	48 dB or more	45 dB or more
K factor (2T pulse)		2.5% or less	4% or less
LF non-linearity	Y	3% or less	
	R-Y/B-Y	4% or less	
Y/C delay		20 ns or less	

Audio

			Metal tape	Oxide tape
LNG	Frequency response (10 dB below standard level (+4 dBm))		50 Hz to 15 kHz +1.5 dB/ -3.0 dB	50 Hz to 15 kHz ±3.0 dB
	S/N ratio (at 3% distortion level)	525	72 dB or more	50 dB or more (Dolby NR OFF)
		625	68 dB or more	62 dB or more
	Distortion (1 kHz, reference level (+4 dBm))		1.5% or less	2% or less
Wow and flutter		0.2% rms or less	0.2% rms or less	

Note

The AFM function is not supported.

Processor adjustment range

Video level	±3 dB/-∞ to +3 dB selectable
Chroma level	±3 dB/-∞ to +3 dB selectable
Setup level	±30 IRE
Chroma phase	±30°
System phase	Sync: ±15 ms
	SC: ±200 ns

Input connectors

HD SDI INPUT (IN/MONI)	BNC (1 each for input and for through output to a monitor) Serial digital (1.485 Gbits/s) SMPTE 292M
REF. INPUT	BNC (2 in loop through connection)
HD	Three-valued (positive and negative) sync signal 0.6 Vp-p, 75 Ω, sync negative
SD	Black burst or composite sync 0.3 Vp-p, 75 Ω, sync negative
AUDIO INPUT (1/2)	XLR 3-pin, female (2) high-impedance, balanced The input level is set with setup menu item 834
TIME CODE IN	BNC

Output connectors

HD SDI OUTPUT (1/2)	BNC (2 for character superimposition) Serial digital (1.485 Gbits/s) SMPTE 292M
COMPOSITE OUT (1/2)	BNC (2 including 1 for character superimposition) 1.0 Vp-p, 75 Ω, sync negative
SDI OUT (1/2)	BNC (2 including 1 for character superimposition) Serial digital (270 Mbits/s) SMPTE 259 M
AUDIO OUTPUT (1/2)	XLR 3-pin, male (2) +4 dBm at 600 Ω load, low impedance, balanced
AUDIO MONITOR OUTPUT (L/R)	XLR 3-pin, male (2) +4 dBm at 600 Ω load, low impedance, balanced
TIME CODE OUT	BNC 1.0 Vp-p, 75 Ω
PHONES	JM-60 stereo phone jack -∞ to -12 dBu at 8 Ω load, unbalanced

Remote connectors

REMOTE	4-pin
REMOTE 9P	D-sub 9-pin, female
VIDEO CONTROL	D-sub 9-pin, female (for optional HKDV-900)

Memory stick slot

Memory stick (8 to 128 MB)

Accessories supplied

Operation Manual	Japanese version (1) English version (1)
CD-ROM manual	(1)
Installation Manual	(1)

Optional accessories

RCC-5G 9-pin Remote Control Cable
HKDV-900 Video Remote Control Unit
BCT-HD12CL Cleaning Cassette Tape
BKP-L551 Battery Adaptor
BP-GL95/GL65/M100/M50 Battery Pack
AC power cord
• For customers in the U.S.A. and Canada
Part No. 1-557-377-11
Plug holder 3-613-640-01

- For customers in the United Kingdom
Part No. 1-782-165-11
Plug holder 3-613-640-01
- For customers in European countries other than the United Kingdom
Part No. 1-782-164-11
Plug holder 3-613-640-01

Design and specifications are subject to change without notice.

To prevent electromagnetic interference from portable communications devices

The use of portable telephones and other communications devices near this unit can result in misoperations and interference with audio and video signals.
It is recommended that portable communications devices near this unit be powered off.

Relation between HKDV-900 setting items and setup menu of this unit

HKDV-900/503 setting items	Setup menu items of this unit
HD Master	740: MASTER LEVEL (HD) ^{a)}
HD Y	741: Y LEVEL (HD) ^{a)}
HD Pb	742: Pb LEVEL (HD) ^{a)}
HD Pr	743: Pr LEVEL (HD) ^{a)}
HD Setup	745: SETUP LEVEL (HD) ^{a)}
HD Sync Phase	746: SYNC PHASE (HD/UC) ^{a)}
HD Fine	747: FINE (HD/UC) ^{a)}
D1 Master	No corresponding menu item
D1 Y	No corresponding menu item
D1 B-Y	No corresponding menu item
D1 R-Y	No corresponding menu item
D2 VIDEO	715: VIDEO GAIN CONTROL (HD/DC/SD/UC) ^{a)}
D2 CHROMA	716: CHROMA GAIN CONTROL (HD/DC/SD/UC) ^{a)}
D2 HUE	717: CHROMA PHASE CONTROL (HD/DC/SD/UC) ^{a)}
SETUP	718: SETUP LEVEL (BLACK LEVEL) (HD/DC/SD/UC) ^{a), c)}
SD Sync Phase	719: SYSTEM PHASE SYNC (DC/SD)
SD Fine	720: SYSTEM PHASE SC (DC/SD)
CROSS COLOR	934: CROSS COLOR (DC)
H CROP POSITION	932: H CROP POSITION (DC)/ 951: H CROP POSITION (UC) ^{b)}
DETAIL GAIN	935: DETAIL GAIN (DC)/ 954: DETAIL GAIN (UC) ^{b)}
LIMITER	936: LIMITER (DC)/ 955: LIMITER (UC) ^{b)}
CRISP	937: CRISP THRESHOLD (DC)/ 956: CRISP THRESHOLD (UC) ^{b)}
DEPEND	938: LEVEL DEPEND THRESHOLD (DC)/ 957: LEVEL DEPEND THRESHOLD (UC) ^{b)}
FREQUENCY	939: H DETAIL FREQUENCY (DC)/ 958: H DETAIL FREQUENCY (UC) ^{b)}

HKDV-900/503 setting items	Setup menu items of this unit
H/V RATIO	940: H/V RATIO (DC)/ 959: H/V RATIO (UC) ^{b)}
GAMMA	941: GAMMA LEVEL (DC)/ 960: GAMMA LEVEL (UC) ^{b)}
CROP	930: CONVERTER MODE (DC)/ 950: CONVERTER MODE (UC) ^{b)}
LETTER BOX	930: CONVERTER MODE (DC)/ 950: CONVERTER MODE (UC) ^{b)}
SQUEEZE	930: CONVERTER MODE (DC)/ 950: CONVERTER MODE (UC) ^{b)}

- a) Valid for output only when VIP.PROC on the P1 PROCS page in function menu is set to MENU.
b) Select whether to set DC or UC with menu item 212 (VIDEO REMOTE CONTROL SELECT). When both are selected (menu item 212 is U&D), both of the corresponding menu settings are made, but this unit's answer values and unity values are the DC values.

HD: HDSDI output during HDCAM playback

DC: Down-converted SD (D1 SDI/COMPOSITE) output during HDCAM playback

SD: SD (D1 SDI/COMPOSITE) output during SD format playback

UC: Up-converted HDSDI output during SD format playback

HD video output phase settings

The HD video output phase is set from the maintenance menu.

For details on the maintenance menu, refer to the maintenance manual.

Item No.	Item Name	Settings
M3	M3A: OUTPUT PHASE SELECT	
	M3A0: HD PHASE SEL	Select the HD video output signal phase with respect to the reference signal: 0H or -90H (HD) advanced. [0H]: Output in sync with the reference signal. -90H: Output with the phase advanced by -90H (HD) to the reference signal.

Note

- The SDDSI (D1) output and component/composite outputs have the same phase.
- The phase of the HD video output and SD video output is fixed to the same phase of the reference signal when up-converted.

Compatibility of playback tape formats

Playback tape format		System frequency			
		50i, 25PsF	59.94i, 29.97PsF	23.98PsF	24PsF
HDCAM	23.98PsF	△	▲	Yes	△
	24PsF			△	Yes
	25PsF	Yes	▲	△	△
	50i				
	29.97PsF	▲	Yes	▲	▲
	59.94i				
	30PsF	▲	△	▲	▲
	60i				
Betacam SX	50i (PAL)	Yes	No	No (A cassette is ejected.)	
	59.94i (NTSC)	No	Yes		
Betacam/SP	50i (PAL)	Yes ^{a)}	No		
	59.94i (NTSC)	No	Yes		

Yes: Both video and audio playback is possible.

△: Both video and audio off-speed playback is possible.

▲: Video only off-speed playback is possible. Audio is muted.

No: Neither video nor audio playback is possible.

a) Playback on PAL models is simple playback quality.

Note

If the playback tape format and system frequency are different, the channel indicator below the audio level meter flashes.

Playback tape format conversion outputs (Up-convert, down-convert)

Playback tape format		System frequency			
		50i, 25PsF	59.94i, 29.97PsF	23.98PsF	24PsF
HDCAM	23.98PsF	No	No	Not down-converted	
	24PsF				
	25PsF	Yes ^{a)}	No		
	50i				
	29.97PsF	No	Yes ^{b)}		
	59.94i				
	30PsF	No	No		
	60i				
Betacam SX	50i (PAL)	Yes ^{c)}	No	--	
	59.94i (NTSC)	No	Yes ^{d)}		
Betacam/SP	50i (PAL)	Yes ^{c)}	No	--	
	59.94i (NTSC)	No	Yes ^{d)}		

a) For 1080/25PsF or 50i, output is down-converted to 576/50i.

b) For 1080/29.97PsF or 59.94i, output is down-converted to 480/59.94i.

c) For 576/50i, output is up-converted to 1080/50i.

d) For 480/59.94i, output is up-converted to 1080/59.94i.

Index

A

- AC IN connector 18
- AC power 20
- AC power indicator 11
- ASMBL display 16
- Assemble editing 43
- Audio data 15
- AUDIO INPUT connector 19
- Audio input level 38
 - Adjusting 38
- Audio level meter 15, 17
- AUDIO MONITOR OUTPUT connector 19
- AUDIO OUTPUT connector 19
- Automatic editing 43, 47
 - Starting 48

B

- Back space editing 39
- Basic setup menu 61
- Battery pack 21
 - Attaching 21
 - Removing 21
- Battery power 20

C

- Cassette 24
 - Ejecting 24
 - Erasure prevention plug 24
 - Loading 24
 - Usable cassette 24
- Cassette compartment 12
- Channel condition display 15
- Channel indicator 15
- Character information 34
 - Adjusting the character display 34
 - Information displayed 34
- COMPOSITE OUT connector 19
- Condition area 15
- CONFI display 16
- Connections 23

D

- DATA/EMPH indicator 15
- DC IN 12V connector 18
- DC operation display 15
- DC power 20
- Digital hours meter 81
 - Displaying 82
- Direct jog/shuttle mode 42

- DISPLAY button 12
- Display window 12, 14
 - Operation display 14
 - Video monitor display 17
- Drop frame display 16
- Duration 44

E

- Edit point 43
 - Automatic setting 44
 - Cueing-up 45
 - Deleting 45
 - Displaying the duration 44
 - Displaying time data 44
 - Modifying 45
 - Preroll 45
 - Setting 44
- E-E mode 13
- EJECT button 12
- Erasure prevention plug 24
- Error message 78
 - Indication 78
 - List 78
- Extended setup menu 64

F

- F FWD button 13
- Format area 16
- Format display 15
- Front panel 11
- Function button 12
- Function menu 29
 - Basic operations 33
 - Configuration 29
 - HOME page 30
 - Item list 30
 - P1 PROCS page 30
 - P2 VIDEO page 31
 - P3 AUDIO page 31
 - P4 TC page 32
 - P5 EDIT page 32
 - P6 OTHER page 33

H

- HD SDI INPUT connector 19
- HD SDI OUTPUT connector 19
- Head cleaning 77
- Headroom indicator 15
- HOME page 30
 - To return 33

J

- Jog mode 42
- JOG/SHUTTEL button 14
- Jog/shuttle display 15

- Jog/shuttle mode playback 42
 - Direct jog/shuttle mode 42

K

- KEY INHI switch 12

L

- LEVEL adjustment knob 12

M

- Maintenance timings 82
- Memory Stick 36
- Memory Stick slot 18
- Menu area 14
- Menu bank 60
 - Recalling settings 60
 - Saving the current active menu settings 60
- Menu bank display 15
- MENU button 12
- Menu operation section 12
- Moisture condensation 81
- Monitor output 46
- MULTI CONTROL knob 13

N

- Names and functions of parts
 - Display window 14
 - Front panel 11
 - Menu operation section 12
 - Rear panel 18
 - Tape transport section 13

O

- Operation display 14

P

- P1 PROCS page 30
- P2 VIDEO page 31
- P3 AUDIO page 31
- P4 TC page 32
- P5 EDIT page 32
- P6 OTHER menu 33
- PAGE/HOME button 12
- PAUSE button 14
- PB LEVEL adjustment knob 11
- PHONES jack 12
- Picture frame in playback 17
- PLAY button 13
- Playback 41
 - Jog/shuttle mode playback 42
 - Preparations 41
- Power sources 20
 - AC power 20

- Battery power 20
- DC power 20
- Supplying power 20
- POWER switch 18
- Power switch 11
- Preroll 45
 - Changing the preroll time 45
- PREROLL button 14
- Preview 46

R

- R/P LEVEL CTL switch 12
- Rear panel 18
- REC button 13
- REC INHI indicator 12
- REC INHI switch 12
- REC LEVEL adjustment knob 11
- REC RUN/FREE RUN indication 16
- RECORDER/PLAYER display 16
- Recording 38
 - Preparations 38
- REF. INPUT connector 18
- Reference timecode 16
- Reference video signal 25
- Remaining battery power display 15
- REMOTE 9P connector 18
- REMOTE button 12
- REMOTE connector 18
- RESET button 12
- REW button 13

S

- SDI input display 16
- SDI OUT connector 19
- Search dial 14
- Search indicator 14
- Sequential recording 39
- Servo indicator 13
- Setup menu 58
- Setup menus
 - Basic setup menu 61
 - Configuration 58
 - Displaying 58
 - Extended setup menu 64
 - Menu bank 60
 - Operations 58
 - Setting 59
- SHIFT button 12
- Shot data 49
 - Displaying 49
- Shot mark 49
 - Cueing up 49
 - Recording 49
- Shuttle mode 42
- Stand 22
 - Replacing 22

- Using 22
- STANDBY indicator 13
- STOP button 13
- Stop code 50
 - Checking the recorded stop code 51
 - Detecting 50
 - Erasing 52
 - Recording 51
- Stop code display 15
- Superimposed data 17
- System configurations 9
- System frequency 16
 - Switching 60

T

- Tape slack 77
- Tape transport section 13
- TIME CODE connector 18
- Time data display area 16
- Time data type 16
- Timecode 26
 - Recording 26
 - Setting an initial timecode value 27
 - Setting to the current time 27
 - User bits 27
- Timecode generation mode 16
- Timecode setup area 16
- Timecode type 16

U

- UMID 53
 - Display 56
 - Output settings 56
 - Recording 53

V

- Video monitor display 17

W

- Warning message 80
 - Setting the warning message to be detected 80

The material contained in this manual consists of information that is the property of Sony Corporation and is intended solely for use by the purchasers of the equipment described in this manual.

Sony Corporation expressly prohibits the duplication of any portion of this manual or the use thereof for any purpose other than the operation or maintenance of the equipment described in this manual without the express written permission of Sony Corporation.

Sony Corporation
B&P Company

HDW-S280 (SY)
3-868-855-02 (1)

<http://www.sony.net/>

2005.04
© 2005